



Restoration Crafts and Practises at Seidla Manor in Estonia

—Sustainable Heritage Report No. 2

Kirsti Horn, editor

Restoration Crafts and Practises
at Seidla Manor in Estonia
—Sustainable Heritage Report No. 2

Novia Publications and Productions,
series S: Student Works, 3/2012

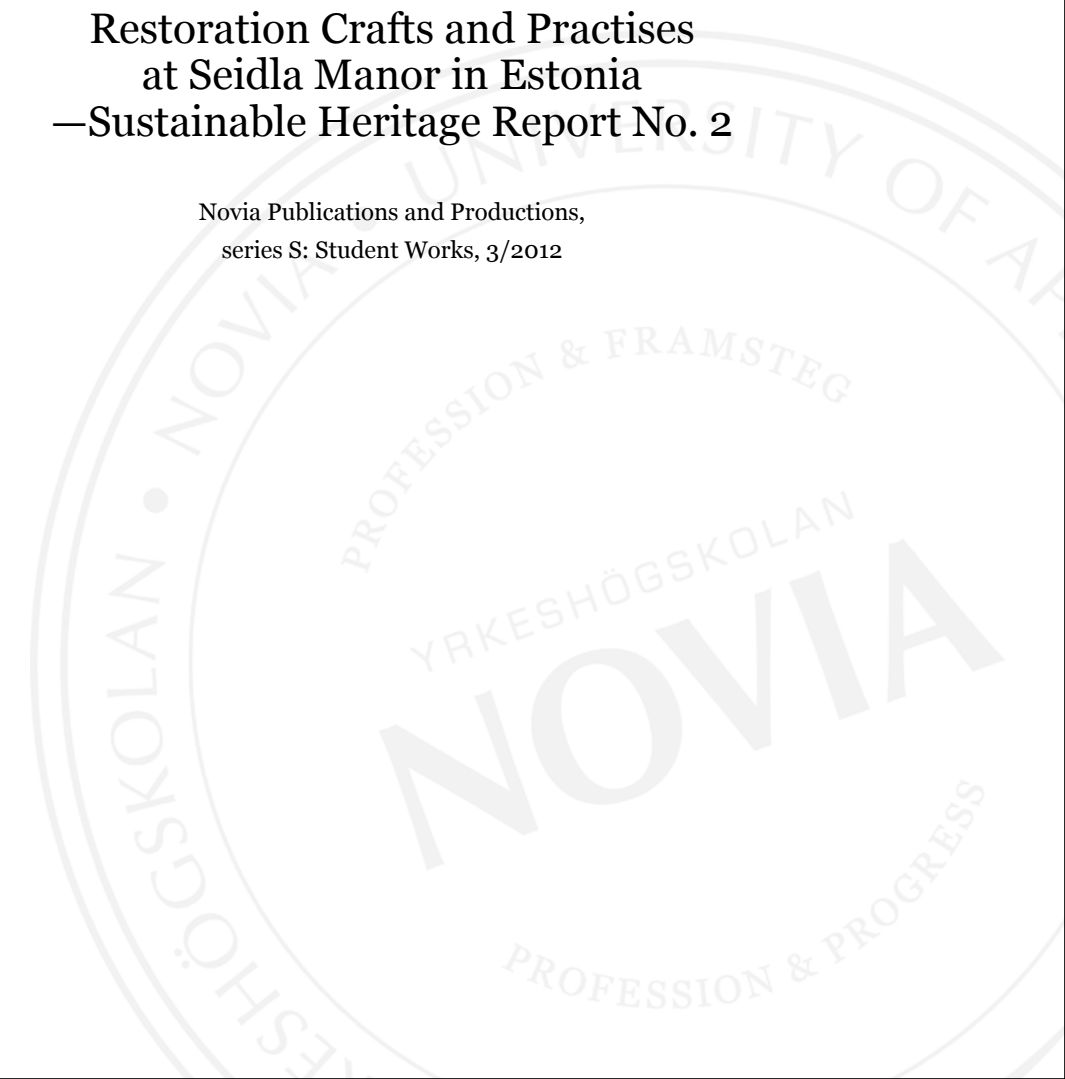

Publisher: Novia University of Applied Sciences, Tehtaankatu 1, Vaasa, Finland

© 2012 Kirsti Horn (editor), and Novia University of Applied Sciences

Text and photographs: *Estonian Academy of Arts*: Anne–Mari Jakobson, Andres Muts, Sandra Mälk, Aigar Needo, Kristiina Piirisild, Kalev Pärn, Maarja Sarv, Maria Silla, Ksenia Tarassova, Kaarel Truu, Vaike Vahter, Pille Vilgota. *Gotland University*: Lars Andersson, Jenny Brunius Petersson, Niklas Martis, Annie Nilsson. *Novia University of Applied Sciences*: Mika Carling, Joni Helander, Kimmo Lahtinen, Fredrik Olin, Jonas Ranta–aho, Jonas Sahlberg, Peter Sjöström, Mikael Törnqvist, Staffan Wackström.

Photographs of wood boring insects: Dr. Uwe Noldt, Thünen–Institut, Hamburg (Germany).

Layout: Michael Diedrichs

Restoration Crafts and Practises at Seidla Manor in Estonia;
Sustainable Heritage Report No. 2 / Kirsti Horn (ed.)

– Vaasa: Novia University of Applied Sciences, 2012.

Novia Publications and Productions, series S: Student Works, 3/2012.

ISSN: 1799-4209 (online)

ISBN (online): 978-952-5839-44-9

Restoration Crafts and Practises at Seidla Manor in Estonia —Sustainable Heritage Report No. 2

Kirsti Horn, editor

A joint project between Gotland University, Estonian Academy of Arts
and Novia University of Applied Sciences.



Contents

Introduction	7
Abstract	9
1. Instructions for making an inventory of windows	11
1.1 Introduction	11
1.1.1 Why make an inventory of windows	12
1.1.2 Why restore	12
1.1.3 Legislation	12
1.2 Preparing for inventory work	13
1.3 Terminology of window parts	16
1.4 Filling in of Inventory Sheets	19
1.4.1 Form sheet for inventory of windows	20
1.4.2 Taking photos	23
1.4.2.1 General view	23
1.4.2.2 Windows	23
1.4.3 Fittings	24
1.4.4 Specifying the condition of the windows	25
1.4.5 Establishing of a grading system for the assessment of condition	29
1.4.6 Grading system	30
1.5 Conclusion	35
1.6 Recommended reading	35
1.7 Overview of fittings	36
2. Mural work at Seidla Manor	41
2.1 Introduction to the mural work project	41
2.2 Introduction to Materials	43
2.2.1 Stones	43
2.2.2 Mortar	44
2.2.3 Renders	46
2.2.4 Roofing tiles	46
2.3 Damage documentation and plans for repair	48
2.4 Hands-on work on gatepost A	53
2.4.1 Used tools	53
2.4.2 Removal of plaster	54
2.4.3 Mixing mortar and plaster	55
2.4.4 Adding new stones	57
2.4.5 Rendering	57
2.5 Sources	60

3. Maintenance of wood in historic buildings	61
3.1 Decay in timber	61
3.1.1 Introduction to wood	61
3.1.2 Reasons for decay in timber	62
3.1.3 Fungal decay	63
3.1.4 Wood-destroying insects in the Baltic Sea Region	67
3.1.5 Recommended reading	75
3.2 Sustainable protection against decay in timber	76
3.2.1 Introduction	76
3.2.2 Linseed oil impregnation	76
3.2.3 Linseed oil paint	77
3.2.4 Wood tar	77
3.2.5 Charring	78
3.2.6 Heat treatment	78
3.2.7 Natural impregnation of pine	78
3.2.8 Recommended literature	79
3.3 Methods for diagnosing the health of timber structures	80
3.3.1 Introduction	80
3.3.2 Measuring devices used at Seidla Manor	80
3.3.3 Other useful devices for the study of timbers and wooden details in historic settings	84
3.3.4 Sources	86
3.4 Repairing of structural timbers	87
3.4.1 Introduction	87
3.4.2 Preparing the logs	87
3.4.3 Different types of splices	88
3.4.4 Repairs with steel and epoxy resin	89
3.4.5 Repairing log constructions	91
3.4.6 Woodwork exercise at Seidla Manor	93
3.4.7 Drawing	98
3.4.8 Literature	100
3.5 Examples of wood repairs at Seidla Manor	101
3.5.1 Windows	101
3.5.2 Cornices	107
Appendix	114
Course Programme 5.–11.9.2010 at Seidla Manor, Estonia	114
About Gotland University	118
About Estonian Academy of Arts	120



Introduction

The current report is the result of joint efforts by students from Estonian Academy of Arts, Gotland University and Novia University of Applied Sciences.

26 students and five teachers from the partner schools in the Sustainable Heritage project gathered at Seidla Manor in September 2010 for an intensive course in the art of repairing manor houses in Estonia. Many manors were visited, many lectures were given and above all, many crafts became familiar through hands-on exercises.

The programme was organised and run by Krista Laido, science secretary, and Mati Raal, associate professor at Estonian Academy of Arts. Professor Joakim Hansson, Juhan Maiste, Kalle Pilt, Maris Suits and Kirsti Horn contributed to the programme with expert lectures and tutoring, each in their special field, while Mati Raal, Taavi Leis, Kermo Jürmann, Tarmo Tammekivi, Andres Ansper gave us practical insight in their crafts and taught us how their tools and materials should be handled.

This was the second course in the *Sustainable Heritage* project which is financed by the Nordic Council of Ministers through Nordplus funds.

The three schools involved take turns in organizing and hosting these annual events. Know-how in the field of conservation is spread through practical exercises which are taught by expert craftsmen. Academic lectures and excursions and other activities are designed to promote cooperation and exchange of ideas between the participants.

Each course is a unique experience in terms of learning about conservation in general and neighbouring nationalities with their traditions in particular. The meeting of building and painting conservators with construction engineers and site managers is also of great value since we all need to cooperate and respect each other's disciplines in order to maintain our built heritage.

We thank Krista Laido and Mati Raal for the inspiring week at Seidla Manor.

Special thanks to Prof. Uwe Noldt of Thünen-Institut (vTI), Hamburg (Germany) for allowing us to use some of his excellent photographs of wood boring insects in this publication.

For this report each nationality specialized in a different subject: the Estonian students on the inventory of windows, the Swedes on repairing masonry and the Finns on subjects related to timber in historic buildings.

The Sustainable Heritage project, together with its follow-up *Traditional Wooden and Masonry Structures in the Baltic Sea Region* are presented through image galleries, professional reports and introductions to past and future courses at the Internet address www.sustainableheritage.fi

Thank you, and see you again at Seidla Manor!

Kirsti Horn, Senior lecturer, Architect SAFA, AA Dipl., together with students from the three cooperating universities.



Hands-On at Seidla Manor in September 2010. Students from Estonia, Sweden and Finland together with our hosts Krista Laido to the left, and Mati Raal in black jacket in the front row.

Abstract

Instructions for making an inventory of windows, part 1

Thorough and correct preliminary work (including inventory) is the prerequisite for the execution of the repairs and restoration work to be done professionally, sparingly and efficiently. Making an inventory is also very useful when collecting the historical data about a heritage site. It explains the technical and cultural value of the building to its restorer and owner.

This manual is divided into different parts according to different aspects of inventory making. Each sub-chapter has a topic giving detailed information about practical questions which every maker of an inventory must deal with.

Mural work at Seidla Manor, part 2

One of the hands-on jobs during the intensive course at Seidla Manor in Estonia was to repair the gate posts of the garden wall. Part 2 of the report starts with an analysis of the materials that have been used to construct and repair these in the past.

This leads to a documentation of damage and finally to suggestions of how to repair these gate posts or any masonry structure of lime stone with similar (also typical) decay. The report can be used as a guideline to sustainable repairs of historical masonry.

Photos of the performed work illustrate students and teachers in action.

Maintenance of wood in historic buildings, part 3

For the Finnish construction engineers and site managers the most useful information and exercises at Seidla Manor were about wood: how its condition can be evaluated and how it should be repaired. This part of the report describes not only the material but also the decay that might occur in it and how it ought to be prevented in a sustainable fashion.

In addition, the hands-on exercises which were performed during the intensive week, are reported in such a way that the reader can apply the described methods for similar situations in his own house.

The best method for all repairs of historic buildings is, of course, to find a well informed and experienced designer, builder and conservator and consult them!

1. Instructions for making an inventory of windows

Estonian Academy of Arts: Anne-Mari Jakobson, Andres Muts, Sandra Mälk, Aigar Needo, Kristiina Piirisild, Kalev Pärn, Maarja Sarv, Maria Silla, Ksenia Tarassova, Kaarel Truu, Vaike Vahter, Pille Vilgota.

1.1 INTRODUCTION

In order to make an inventory of a building, one has to know facts about its historical background as well as about its present condition. It is also necessary to take into account all the major previous repairs and restoration work.

Start by describing:

- the location of the building;
- the owner of the building;
- the dimensions of the building;
- if it is a heritage site or not;
- all the written material (documents, drawings, historical plans, photos) using archives and bibliography;
- previous repairs and restoration work.

The structure of this manual makes it easy to find concise information about making an inventory of windows. A more demanding reader will find thorough information and recommendations for the planning of an inventory job as well as for executing it. This manual deals firstly with general principles and concepts of inventory work, then gives general information of what is needed in order to make an inventory, and finally gives specific instructions on how to fill in inventory sheets.

1.1.1 WHY MAKE AN INVENTORY OF WINDOWS

The purpose of the inventory is to document the present condition of the windows, the expected life span, durability and deterioration of their different parts and materials.

The inventory gives information for the forthcoming restoration. It is the first step and foundation for restoration work.

1.1.2 WHY RESTORE

Good building traditions and materials are long lasting both technically and aesthetically. The quality of historical windows has often proved better than that of modern windows. The materials were chosen with good care and much more attention was paid to the aesthetics of its details and the window as a whole. Also handmade craftwork is always valuable as it represents the fashion and technique of its era and region. Old windows are sustainable and it is generally possible to repair them with fairly simple although time consuming means. Naturally, good and regular maintenance will make them last longer and postpone the need of heavy reconstruction. New copies of windows are often made in a simplified technique of lesser quality materials and poor details. As sustainability and environmental issues are important all over the world old windows and other removable parts of buildings should be given next chance through repair or reuse.

1.1.3 LEGISLATION

In the Republic of Estonia the order of the conservation, restoration, repair or construction of monuments or of structures located within heritage conservation areas—as well as the compilation of the project for constructions, and the conduct of prior studies and the compiling of special conditions for heritage conservation—is regulated by the decree of the Estonian Ministry of Culture¹.

Countries have different legislations. Before making an inventory it is necessary to examine the regulations of the actual area in order to fulfil the local requirements in ones work.

¹ Elektroonline Riigi teataja <https://www.riigiteataja.ee/ert/act.jsp?id=606847> (vaadatud 20.9.2010).

1.2 PREPARING FOR INVENTORY WORK

Necessary means: paper, pencils, camera, all plans and facades of the building stickers, knife or sharp awl.

In order to be able to begin inventory work it is vital to have an overview of the building and a clear picture of the aimed result. Before starting to examine e.g. the windows, one has to clarify how much and what kind of information is needed.

1. First of all it is necessary to mark each window on all plans or all facades, labelling every window with a letter and a number e.g. W-1 and W-2 (W for window). The letter indicates the kind of construction we are dealing with: Usually windows are marked 'W' and the doors would have letter 'D'. This kind of labelling makes the work faster and systematic. The place where to start numbering is not as important as the fact, that each window should have its own unique code which will later be used in the header of the inventory sheet. All the windows must be taken into account, including the balcony windows and small windows in the cellar or the roof. If there is not any ground plan available from archives, then it has to be drawn schematically on the spot. The inner and outer casements do not have to be numbered separately, because they will be dealt with separately on the inventory sheet.

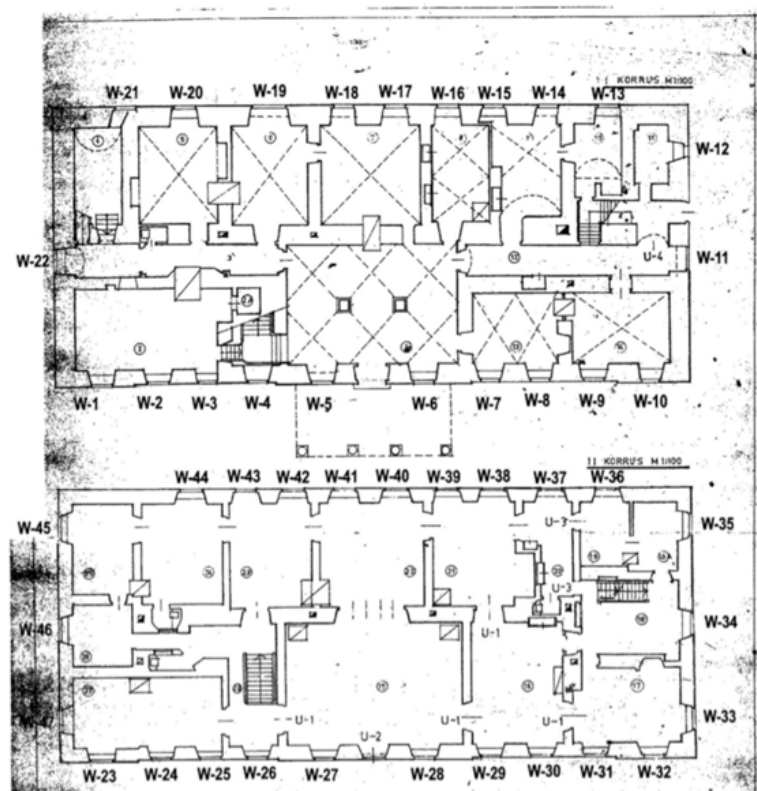

Figure 1.1. Plans of Seidla Manor with the window labels.

2. When the paperwork is prepared, the inventory work can begin. The first step is to observe visually all the windows of the building, in order to obtain a reasonable overview of the different shapes and types. Every window should be marked with a sticker carrying the code as indicated on the plan or facade. Only then, every window has to be examined by its shape and size in order to determine the type. In this way it is easy to figure out how many windows from different periods there are. Most common historical window types in Estonia are presented in figure 1.2.

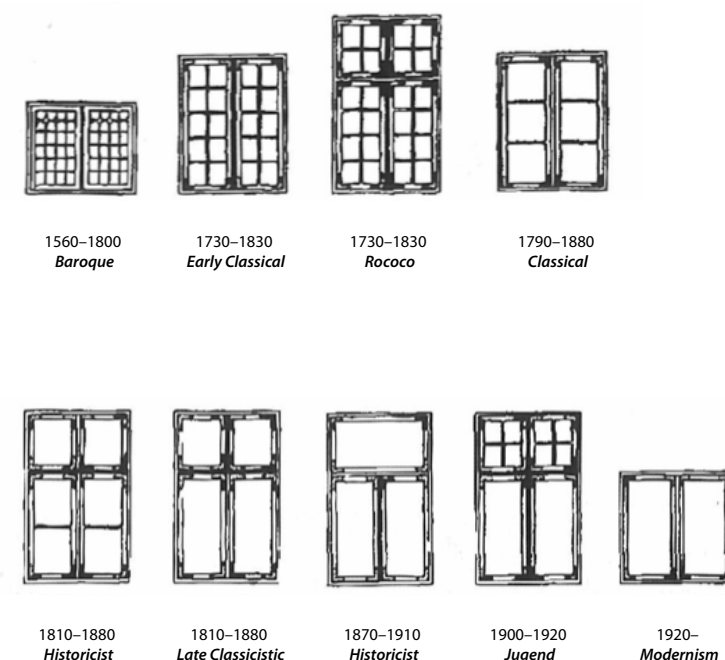

Figure 1.2. Common window types in Estonia.²

In order to determine window types, one has to look at the general shape of the frame/casement as well as count the number of window panes. For instance, should the window W-1 have six panes, it will be marked as T-1 (type 1). If the next window has eight panes, then this will be the second type, marked as T-2. If a window has six panes but the upper part is curved, then this will be distinguished as a different type, e.g. T-3. Attention should also be paid to thickness or profile of the frame/casement. When it is significantly different from other windows, then this should be marked as another type because it is likely to be of a different date. Also, the windows with vent lights make another type. It is useful to make a drawing of all window types to make it easier to compare differences. Some buildings have only two or three different types

² Akende tüübid. Puitaknad. Eesti Muinsuskaitseameti ja Pärnu Linnavalitsuse teabekiri. 2010, lk 3 (corrections and translation by the editor).

of windows, whereas another building may have twenty or more. Eventually, every window has to have two references: the code (e.g. W-1) and the type (e.g. T-3). When the windows have been counted and typologised, it is time to fill in the inventory sheet.

1.3 TERMINOLOGY OF WINDOW PARTS³

Angle bar—an upright bar at the meeting of two faces of a window.

Astragal—a member, or combination of members, fixed to one of a pair of doors or casement windows to cover the joint between the meeting stiles and to close the clearance gap; provides a weather seal, minimizes the passage of light and noise, and retards the passage of smoke or flame during fire.

Bottom Rail—the lowest horizontal structural member of a door or window, which interconnects the stiles.

Casement or sash—the framework of a window made up by the two vertical stiles on top and bottom rails. Casement is usually referred to when it is hung on hinges, whereas sash is used to refer to a window that slides up and down. In continental Europe casement is widely used. Different casements: outside is summer casement and inside is winter casement.

Crank—a strip of material which is fixed across a frame to make it rigid.

Cremona—a rotating handle actuates sliding rods which move in opposite directions, extending from the edges of the window into sockets that are fixed in the frame.

Double casement—joint outer and inner casements.

Dowel—a cylindrical wood or metal rod; used to secure two pieces of wood, stone, concrete etc., by inserting it in a hole through the two members.

Fittings—devices or mechanisms for opening, closing, supporting, holding open or locking the sashes, including such items as catches, chains, cords, fasteners, hinges, lifts, locks, pivots, pulls, pulleys, sash balances, sash weights and stays.

³ Harris, Cyril, M. Ed. Dictionary of architecture and construction. New York: McGraw-Hill, 1975.

Fixed light—the glazed part of the window that is not hinged or opening. i.e. it is fixed in position. A window or an area of a window which does not open; glazed directly in a fixed frame that does not open.

Frame—the fixed, nonoperable frame of a window designed to receive and hold the sash or casement and all necessary hardware.

Glass—(a hard, brittle inorganic substance, ordinarily transparent or translucent; produced by melting a mixture of silica, a flux and a stabilizer) or, **glazing**—(setting glass in an opening; the glass surface of a glazed opening) or,

light—an aperture through which daylight is admitted to the interior of a building; a pane of glass, a window, or a compartment of a window.

Glazing bead—around a glazed opening, removable trim that holds the glass firmly in place (instead of putty).

Hinge—a movable joint used to attach, support and turn a window about a pivot; consists of two plates joined together by a pin which support the window and connect it to its frame, enabling to swing open or closed.

Hook—a curved or bent metal device used for attachment.

Mullion—wide vertical piece of wood that separates panels in a multi panel window. The central vertical members that may frame a window. A vertical member separating (and often supporting) window, doors, or panels set in series.

Muntin bar—wide vertical piece of wood that divide glass light. A secondary framing member to hold panes within a window, window wall, or glazed door. An intermediate vertical member that divides the panels of a door

Pane—a flat sheet of glass, cut to size for glazing a window. Often of small size, larger ones being usually called 'sheets'. Once installed the pane is usually referred to as light or window light.

Putty—a heavy paste composed of pigment, such as whiting, mixed with linseed oil, used to fill holes and cracks in wood prior to painting to secure and seal panes of glass in window frames.

Sash—a frame in which panes of glass are set in a window or sometimes a door. The sash is usually referred to in sliding windows. e.g. opening sash, fixed sash. Any framework of a window; may be movable or fixed; may slide in a vertical plane (as in double-hung window) or may be pivoted (as in casement window).

Shutter—a movable screen or cover used to cover an opening a window.

Sill—a horizontal timber, at the bottom of the frame of a wood structure, which rests on the foundation The horizontal bottom member of a window frame.

Sill flashing—the horizontal part at the base of a window that forces water to run off and away from the building.

Stile—one of the upright structural members of a frame, as at the outer edge of a door or a window sash.

Tenon—the projecting member of a piece of wood, or other material, which is reduced in cross section, so that it may be inserted in a corresponding cavity (mortise) in another piece in order to form a secure joint.

Top Rail—the top horizontal member of a casement or sash.

Transom—the central horizontal member of a window.

Weather moulding—an extending wooden strip (part of sash) for draining off the water.

Vent light—an opening part at the top or bottom of a window, hinged at either its top or bottom rail. If hinged at the top it opens out and if hinged at the bottom it usually opens in. A small operable (light) pane with hinges along its upper edge, so that it may be swung open to provide ventilation without opening the entire sash/casement.

Window—an opening in an external wall of a building to admit light and air; usually glazed. An entire assembly consisting of a window frame, its glazing and any operable elements.

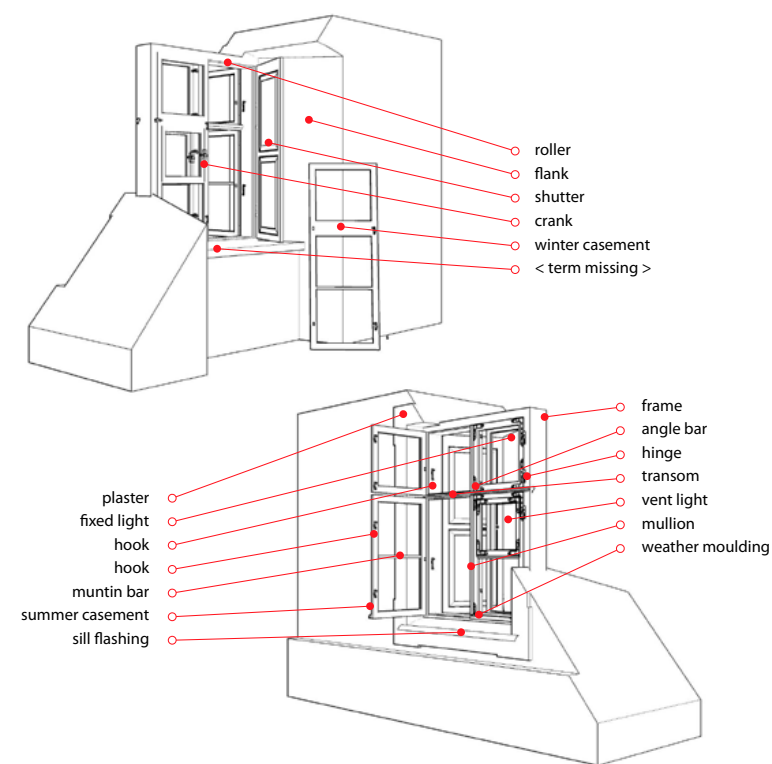

Figure 1.3. One of the most typical window types in Seidla (view from inside and outside).

1.4 FILLING IN OF INVENTORY SHEETS

Best results for an inventory can be obtained by making the inventory sheet in the form of a table. The advantages of this kind of form are clarity and coherence, which make it possible to specify the condition of the windows in great detail. Filling in the form will save time and is effective in minimizing the possibility of shortcomings in survey. The form must be structured in a clear and unambiguous way and filled in with great detail and care. It is much easier to plan the restoration work, if the inventory sheet gives thorough and accurate information.

1.4.1 FORM SHEET FOR INVENTORY OF WINDOWS

The inventory sheet has to contain the following information:

- General data: name and address of the building, the ground plan of the house with all the windows marked on it, name of the inventory maker, date, window code, drawing and photo from both inside and out, notation of different type of windows; approximate dating, information about shutters and other extra details.
- Types and number of fittings: hinges, cremonas, hooks, angle bars, cranks etc.
- Schematic presentation of damages: marked on the drawings these should point out all the damages schematically and all the missing details whether wooden parts, glazing, putty, fittings or others.
- Classification of the condition of frame and the inner and outer casement according to a five-point grading system (see: evaluation of condition, chapter 5.3)
- Detailed description for restoration of frame and inner and outer casements separately (including wooden parts, finishing, glass, putty and fittings).
- Additional remarks if necessary.

Figure 1.4 a, b. Form sheet for inventory of a window: general information, existing fittings, restoration necessities. Download PDF version at project site http://www.sustainableheritage.fi/form/SH-Sheet_InventoryOfWindows.pdf

INVENTORY SHEET

Object	Seidla manorhouse Järvamaa, Estonia	Window symbol	W-
Inventory taker		Date	06.09.2010

OUTER WINDOW		INNER WINDOW	
Photo from outside:		Photo from inside:	
Type		Type	
Approx. dating		Approx. dating	
		SHUTTERS:	YES / NO

EXISTING FITTINGS

Hinges		Hinges	
Type	Pieces	Type	Pieces
Cremona bolts		Cremona bolts	
Type	Remarks	Type	Remarks
Cranks		Cranks	
Type	Pieces	Type	Pieces
Hooks		Hooks	
Type	Pieces	Type	Pieces

Angle bars		Angle bars	
Type	Pieces	Type	Pieces
REMARKS:		REMARKS:	
OUTER WINDOW		INNER WINDOW	
Photo from outside; mark the deteriorations on it		Scheme of damages	

Red color – wood; blue color – glass; green color –putty/glazing bead; black color – fittings

Condition rating	Condition rating
1 – very bad (needs to replace) 2 – bad (needs a lot of restoration, structural repairs) 3 – satisfactory (needs restoration) 4 – good (mainly finishing works are needed) 5 - very good (nothing is need to be done)	

RESTORATION NECESSITIES

FRAME			
OUTER SASH		INNER SASH	
Wooden parts		Wooden parts	
Finish		Finish	
Glass		Glass	
Putty/glazing bead		Putty/glazing bead	
Sill flashing		Sill	
Fittings		Fittings	
REMARKS		REMARKS	

1.4.2 TAKING PHOTOS

In addition to text, photography is an essential method in preserving information about the windows. While making an inventory of the windows of a building one should take photos of of the whole building or facades as well as of the details of the windows.

1.4.2.1 GENERAL VIEW

1. General views should be taken from all sides of the building or at least from the diagonal corners.
2. It is recommended to take pictures in cloudy weather. Sharp contrast on photos does not give best results, because it is hard to gather information from dark areas of a photo.
3. If the trees are overshadowing the general view, it is recommendable to take the photo, while the trees are without leaves.
4. In order to avoid perspective distortion, it is recommended to take a picture from a reasonable distance, so that the horizon would be in the middle, and the house itself on the upper part on the picture. Later on, it is possible to cut the undesired part of the photo and manipulate distortions, colour and light on digital photos.

1.4.2.2 WINDOWS

1. All windows must be photographed from both sides.
2. Before taking a picture, one must put a sticker with the window code on the window or next to it, so that it is easy to recognize where the photo was taken.
3. If one is taking a photo from the inside, it is recommendable to use flash in order to balance the glare through the glass.
4. The photo of a window can be used as a draft for the scheme of damages, but it is better to make drawings of windows for that purpose.
5. Choose the best sample to illustrate each window type.
6. Take photo samples of different fittings.

1.4.3 FITTINGS

Fittings are used for practical purposes: e.g. angle bars strengthen the joints; hinges, hooks and Cremonas help to close the window. In addition, fittings give a lot of information about the historical style of different periods. See figures 1.5 and 1.8 a–d for the different types of ironmongery that could be found on the windows of Seidla Manor.

Of course, it is not enough to give dating relying upon the shape of a fitting, because very often these were reused over the centuries. The same applies to the glazing.⁴

- Specify different types of fittings. Take photos of all the existing fittings by their types. Choose sample photo of each type of fittings and label each type with different code (number and letter).
- On the inventory sheet mark all the existing fittings on the drawing or on the photo of the window.
- Mark on the inventory sheet the type and the number of fittings.
- Fittings from different periods, which are not included in typology, could be marked down separately (e.g. in the remarks section).
- Grade the condition of existing fittings; add suggestion for repairs or replacement.
- Shutters should be dealt with separately.

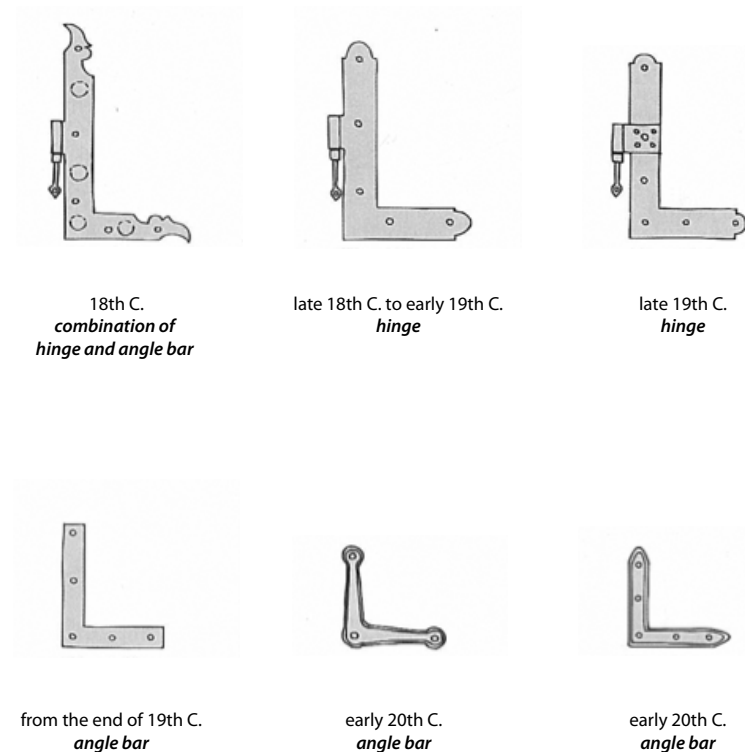

Figure 1.5. Examples of historical fittings in Estonia.

1.4.4 SPECIFYING THE CONDITION OF THE WINDOWS

Very often the amount of restoration work exceeds the planned working programme. The common reason is that small details were not included in preliminary studies (inventories) of the object. (It is only through systematic and thorough preparatory work that we can minimize the risk of underestimating the extent and consequently the cost of restoration work. Condition rating limited only to ocular observation is often insufficient, because in many cases the extent of deterioration will be visible only when layers of paintwork are removed or the structure of the window is revealed. In addition to visual observation simple measures can be put into practice to test the strength of

⁴ Muinsuskaitseameti infovoldik nr 5. Akende ajalugu, puitaken ja selle remontimine <http://www.muinas.ee/files/5.%20Akende%20ajalugu,%20hooldus%20ja%20remontimine.pdf>

wooden parts. Windows should be tested through such simple mechanical means as knocking, touching and opening.

In the following important points are discussed to which one should pay attention, in order to gain understanding of the condition of a window.

Structural condition: historically the joints of a casement were never glued, but fastened with two wooden pegs through corner joints. This kind of casements can be easily dismantled and repaired.

Check:

- Is the frame fastened and sealed properly? What is the material between the frame and the wall?
- Is there any deterioration of the timber?
- Tap the glass gently. If it rattles the putty must be repaired or redone altogether.
- Check general stability of the casements and the condition of corners and lower wooden members. Are the pegs missing or do they stick out? An experiment (after the glazing has been removed): hold the casement with both hands and try to squeeze it from opposite corners—in case it flexes or warps it should be repaired.
- Is water getting into the structural joints of the frame or casement?
- Is the window foggy? If condensation appears on the outer glass, the inner casement is sealed insufficiently.
- Are the joints of the casement fastened properly? Are astragals and weather-mouldings fastened properly or is there a crack in between them which gathers water?

Closing of window

Check:

- Is the window opened or closed easily? Is the window closed tightly enough or too tight? (The inner window has to be sealed more tightly than the outer; this reduces condensation on the outer glass).
- Does the casement need sealing?

Wooden parts: the deterioration of wood is usually caused by excessive moisture. The solidity of wood could be tested by using a sharp object such as an awl (as a result a broken piece with long fibres indicates good condition of the timber; if the material comes away in short crumbles, then the timber is rotten). For the determination of the surface layer of timber the professionals also use a mechanical penetration device called Pilodyn.

Check:

- The condition of the wood: fungal decay; the effects of the sun and UV radiation (timber turns gray and 'hairy'); mechanical damage; insect attack. Due to weathering the lower part of the window has usually suffered more damages than the rest.
- Mechanical damage: broken wood, glass, putty or fittings can cause leakage and consequently also biological deterioration
- Previous repairs: these might have failed.

Finishing: the best choice for wooden windows is linseed oil paint. Other types of paint—acrylic or alkyd—must be removed.

Check:

- What kind of paint and colour has been used?
- How many paint layers are there? (For restorers: what kind of structure, order and colour do the paint layers have?)

- What is the condition of the paint: is the layer solid or cracked? To what extent? Should the window be stripped of all old paint and repainted entirely?

Glazing: the glasses of historical windows look often wavy and contain bubbles. This kind of glass is not produced today, and therefore it is very valuable. This kind of glass is generally thinner than modern glass, and it would be good to reuse it. Putty is used traditionally to fasten glasses to window panes. But the putty is very often replaced with glazing beads. However, it is recommended to use putty instead of beads, because the putty lasts much longer.

Check:

- Document missing or broken panes.
- Determine the method of manufacturing of the glass and its likely date: the oldest glass (up to the 1930's) was blown and hand made. It has bubbles and imperfections of all kinds. Early industrial glass (from the early 1900's to the 1950's) was produced by drawing the molten mass of glass through a series of rollers. This is why it is wavy. Modern glass (from 1960 onwards) is almost too perfect for old windows.
- Decide the method of glazing –putty or glazing beads.
- What is the condition of the existing putty—crumbling or cranking; estimate the amount of good putty (%).
- It is obligatory to check whether the glass is loose (even if it looks good from outside). The method is to knock gently on the glass: rattling indicates insufficient fastening.

Fittings and sill flashing: together with the fashion of wooden details the style of the fittings on a window tells its history, the date of production and later repairs. It is important to respect this and never replace a functioning piece of ironmongery. Sometimes the solution is to leave a valuable broken piece in its position and attach a new one next to it.

Check:

- Are the angle bars firmly fastened?
- Are the hinges firmly fixed to the frame and the casement or are the joints loose?
- Are the crémones, hooks etc. working properly? Do they fit correctly into their sockets?
- Do all fittings have sockets?
- What is the condition of the fittings? Are they rusty, clean metal, painted?
- What kinds of fastening materials are used? (Nails, screws, or other?)
- Is the sill flashing whole and well fastened?

1.4.5 ESTABLISHING OF A GRADING SYSTEM FOR THE ASSESSMENT OF CONDITION

If the assessment of condition is carried out by different groups or persons, it is necessary to establish a fool-proof and unambiguous grading system for the grading of deterioration or damages of windows. The degrees of the grading should be laid down in written form (if there is a group of people) or explained explicitly between persons involved (if there are few persons involved in the project). General gradation should give an overview of the condition. If different persons evaluate deterioration in different ways, the outcome or overview of grading is not objective!

1.4.6 GRADING SYSTEM

- **1: very good**—window does not need any repairs. Finishing, wooden structure, sill flashing, fittings and other details are in perfect order. Windows can be opened and closed easily and tightly enough.
- **2: good**—it is necessary to redo the finishing or to repair/replace some fittings. Window is air tight, in reasonably good order and functions normally.
- **3: satisfactory**—the structural parts of window are strong and without damages. Worn out paintwork, broken glazing, putty or sill flashing has to be repaired or replaced. Some wood work is necessary.
- **4: bad**—wooden structure of the window is falling apart, the paintwork has to be replaced. Glazing and sill flashing have to be replaced. Old putty has to be removed and new applied. Wooden parts need a lot of reparation because it is damaged by weathering, fungi or insects. The window does not close properly. Many fittings are missing or broken.
- **5: very bad**—Large parts of the window are missing or so severely damaged that most of the window or the whole window has to be replaced...

INVENTORY SHEET

Object	Seidla manorhouse Järvamaa, Estonia	Window symbol	W-19
Inventory taker		Date	06.09.2010

OUTER WINDOW		INNER WINDOW	
Photo from outside:		Photo from inside:	
			
Type	W07	Type	W16
Approx. dating	Tsarist time	Approx. dating	Tsarist time
		SHUTTERS:	YES / NO

EXISTING FITTINGS

Hinges		Hinges	
Type	Pieces	Type	Pieces
HI-0	3+0,5	HI 1	4
HI-1	2+2x0,5		
Cremone bolts		Cremone bolts	
Type	Remarks	Type	Remarks
		Removed 2 tk	
Crankes		Crankes	
Type	Pieces	Type	Pieces
		CR-8	6
Hooks		Hooks	
Type	Pieces	Type	Pieces
HO-6	5 (/2 broken)		
HO-1	3 (/1 broken)		

Figure 1.6 a, b. Filled sheet for inventory of window W-19 at Seidla Manor; produced by the team on site. 6.9.2010.

Angle bars		Angle bars	
AB-1	6		
AB-6	18		
AB-7	4		
REMARKS: Fortushka has 2 more hinges		REMARKS:	
OUTER WINDOW Photo from outside; mark the deteriorations on it		INNER WINDOW Scheme of damages	
			

Red color – wood; blue color – glass; green color –putty/glazing bead; black color – fittings

Condition rating	Condition rating
1 – very bad (needs to replace) 2 – bad (needs a lot of restoration, structural repairs) 3 – satisfactory (needs restoration) 4 – good (mainly finishing works are needed) 5 - very good (nothing is need to be done)	

RESTORATION NECESSITIES

FRAME			
OUTER SASH		INNER SASH	
Wooden parts	mainly finishing works are needed	Wooden parts	mainly finishing works are needed
Finish	Satisfactory, needs restoration	Finish	mainly finishing works are needed
Glass	1 broken glass, 4 glasses are combined with multiple sheets	Glass	2 broken, 4 missing
Putty/glazing bead	Upper part 2 glasses loose, lower part 1 glass loose.	Putty/glazing bead	mainly finishing works are needed
Sill flashing		Sill	A part is missing
Fittings	mainly finishing works are needed	Fittings	2 cremone bolts missing
REMARKS		REMARKS	2 shutter panels are missing

When all the windows have been studied, a conclusion is made so that an overall estimate of time and cost can be made for the restoration work that is needed.

The following conclusion describes the state of 9 of the windows at Seidla Manor. Maintenance has been neglected, there has been an obvious shortage of glazing putty and a lot of glass has been destroyed due to vandalism. Yet, many windows can be saved if they are fixed soon. They tell their story of the fate the building has undergone over the years, and therefore as much of this evidence as possible should be allowed to show.

**INVENTORY OF WINDOWS (W1-W5 & W18-W21)
CONCLUSION**

AVERAGE CONDITIONAL RATING			
OUTER WINDOWS		INNER WINDOWS	
2,5- between bad and satisfactory in general, need a lot of restoration		2,5- between bad and satisfactory in general, need a lot of restoration	
Among them:			
outer windows		inner windows	
1 – very bad condition		4 – very bad condition	
1 – bad condition		1 – satisfactory	
5 – satisfactory		4 – good condition	
2 – good condition			
FRAMES			
Frames are either in a good condition – need cleaning and repainting or satisfactory in general – need restoration. Some frames need replacements. At least 3 of them (frames) are in a good condition and 3 among all is bad.			
OUTER SASH		INNER SASH	
Wooden parts	On the whole there are three variants. Good condition – don't need repairing (at least 3 examples), satisfactory – need restoration. In some places the wooden parts are missing (at least 4 examples).	Wooden parts	On the whole there are three variants. Good condition – don't need repairing, almost missing or totally missing. (4)
Finish	The most typical is when the finish needs to be cleaned and repainted with the linen seed oil paint. Sometimes there is no finish at all.	Finish	Generally the upper layer needs to be removed because of its low quality. In some places the finish is almost or totally missing.
Glass	Glass is loose in general – glazing panes need to be replaced. 17 glazing panes need to be replaced	Glass	38 glazing panes need to be replaced

Figure 1.7. Conclusions for inventory of windows W1–W5 and W18–W21 at Seidla Manor.

1.5 CONCLUSION

The first part of this publication is a manual which is divided into sections according to different aspects of inventory making. Each sub–chapter has a topic giving detailed information about practical questions which every maker of an inventory must deal with. The value of this manual is in detailed answers to most question that may arise during an inventory process. The different aspects of inventory are presented systematically, putting the parts of the process into logical sequence and therefore making it easy to use.

Thorough and correct preliminary work (including inventory) are the preconditions for the execution of the repairs and restoration work to be done professionally, sparingly and efficiently. *Making an inventory* is also very useful when collecting the historical data about a heritage site. It explains to the restorer and the owner the technical and cultural value of the building.

1.6 RECOMMENDED READING

- Akende tüübid. Puitaknad. Eesti Muinsuskaitseameti ja Pärnu Linnavalitsuse teabekiri, 2010.
- Aknad. Ajalugu ning nõuanded parandamiseks. Rootsi Riigi Muinsuskaitseamet, 1997.
- Harris, Cyril, M. Ed. Dictionary of architecture and construction. New York: McGraw–Hill, 1975. Keskküla, Liis. Tallinna vanalinna ajaloolised puitaknad. Juhendmaterjalid projekteerijatele ja restaureerijatele. Eesti Kunstiakadeemia Muinsuskaitse ja restaureerimise osakond. Magistritöö. Tallinn, 2007.
- Täheväli Stroh, Lea. Vana aken. Praktilisi nõuandeid puitakende korrastamiseks ja hooldamiseks. Maja tervis 2. Tallinn, 2005.
- Muuseumitekstiilid. Materjalide kahjustumine. Objektide seisundi hindamine. http://www.kanut.ee/kkoda/dokumendid/tekstiil/tekstiilmaterjalid_kahjustumine_seisund.doc

1.7 OVERVIEW OF FITTINGS





Figure 1.8 c. Cranks and hooks: CR-(1-3) and HO-(1-6).



Figure 1.8 d. Angel bars: AB-(1-8).



Figure 2.1. Students learning about mortars and restoration of stone walls. Teachers Taavi Leis (*left*) and Kermo Jürmann introduce correct materials and tools. Gateposts which are to be restored stand in the background waiting for their restorers. *From left:* gatepost A (Swedish students), B (Finnish students) and C (Estonian students).

2. Mural work at Seidla Manor

Gotland University: Lars Andersson, Jenny Brunius Petersson, Niklas Martis, Annie Nilsson.

2.1 INTRODUCTION TO THE MURAL WORK PROJECT

During our time at Seidla Manor one of our tasks was to repair the tops and surfaces of three gate posts of the garden wall. The work was documented and the following report gives an introduction to the materials in the wall and the work that was done to repair the masonry construction.

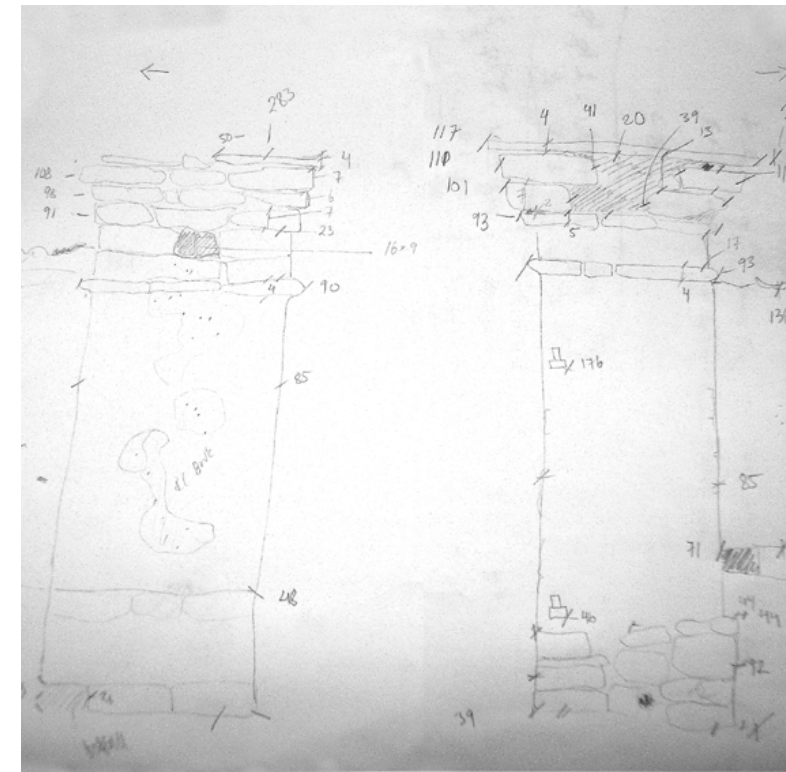

Figure 2.2. A documentation drawing of gateposts A and C.



2.2 INTRODUCTION TO MATERIALS

2.2.1 STONES

The garden wall at Seidla Manor is mainly constructed of limestone which is a local sedimentary rock. A noticeable feature is its layering and fossils of shells, bones and invertebrate animals that can be detected in it.

In this wall the biggest and flattest stones are at the bottom of the footing. The following layers are built with smaller, flat stones of similar sizes. The gateposts had originally thin flat topping stones that protected them from rain and wind. Two of these were broken.

Figure 2.3. The gate has fallen off long ago and many generations of repairs can be detected in the masonry of both wall and gate post C.

2.2.2 MORTAR

The wall was originally constructed with lime mortar, fixing the limestone together. Later most parts of the wall have been repaired with a mortar consisting of lime and cement.

Both lime and cement are binding materials. The two materials perform their binding function very differently. The lime binder maintains an open pore structure when dry, whereas a cement binder dries with a denser pore structure. The lime also maintains a degree of flexibility that gives the mortar an ability to move with the wall. Cement on the other hand dries rigid and hard and is unable to move with the structure.

One way of seeing the difference between mortars is the color. Lime mortar is usually yellow or white and cement mortar is gray.



Figure 2.4. Decayed mortar allows rain and frost into the structure thus accelerating the process of deterioration.

2.2.3 RENDERS

It is not very clear what the finishing layer of the garden wall at Seidla Manor originally was. A thick layer of render is most unlikely though, as that would have left clearer traces.

It is more likely that the wall has been brushed with a very thin layer of render. When doing this the mortar that had been pushed out of the construction when building the wall, would have been brushed out evenly over the wall and when needed, extra render would have been added to fill cavities. With this method the shapes of the stones would still be clearly visible but the surface would give an even impression. Some traces that might point in that direction have been found but there is no definite proof.

The wall might just as well have been left untreated. The construction is stable enough for both options, so the choice would have been based on aesthetic values.

2.2.4 ROOFING TILES

Instead of flagstones roofing tiles can be used as a top layer to protect the top of a wall. This is the case on most parts of the garden wall at Seidla Manor. The top of the wall has been built with a slope, using broken roofing tiles as a filling and a cement mortar to fix it together. This is clearly a later addition as the mortar is newer than the old lime mixture, and the roofing tiles are also of a younger date than the wall itself. Some parts of the wall have been left without this addition. There the top layer consists of lime stone and has a slight angle to lead the water off.



Figure 2.5. The terracotta roofing tiles are a later addition to the wall. The installation might not look very elegant but at least it prevents rain from entering the structure.

2.3 DAMAGE DOCUMENTATION AND PLANS FOR REPAIR

Missing Stones (1)—stones have fallen out, leaving the mortar unprotected from rain and providing a positive environment for vegetation to grow.

Repair: clean the surface and remove all loose stones, old mortar in bad condition, dirt and vegetation. Find new stones to replace the missing ones. Fix the stones back into their original position with lime mortar.

Broken Topping Stone (2)—the big flagstones of limestone that originally covered each post were broken, allowing water to enter the construction.

Repair: remove the broken pieces of the old topping stones and replace them with new ones of appropriate size. Clean the surface underneath and remove old bad mortar, dirt and vegetation. Lay the new flagstones on a bed of lime mortar.

Mortar (3)—the stones that have fallen out have let water into the construction, slowly destroying the binding ability of the mortar and turning it partly into sand. This has become a good environment for vegetation to grow, leading more water into the construction. This together with growing root systems is the main reason for damage in the wall construction.

Repair: while taking down loose stones it is also important to remove the mortar that is no longer performing its function. When making a new mortar mix it is important to examine the old one and to make the new with equal density and hardness.

Render (4)—thin layer of cement based render has been applied on the construction.

Repair: remove all the cement render and apply new lime mortar in the revealed cavities.

Bricks (5)—missing lime stones have been replaced by bricks which in their turn have gone bad from moisture.

Repair: remove all brickwork and surrounding mortar. Repair with suitable pieces of limestone and lime mortar.

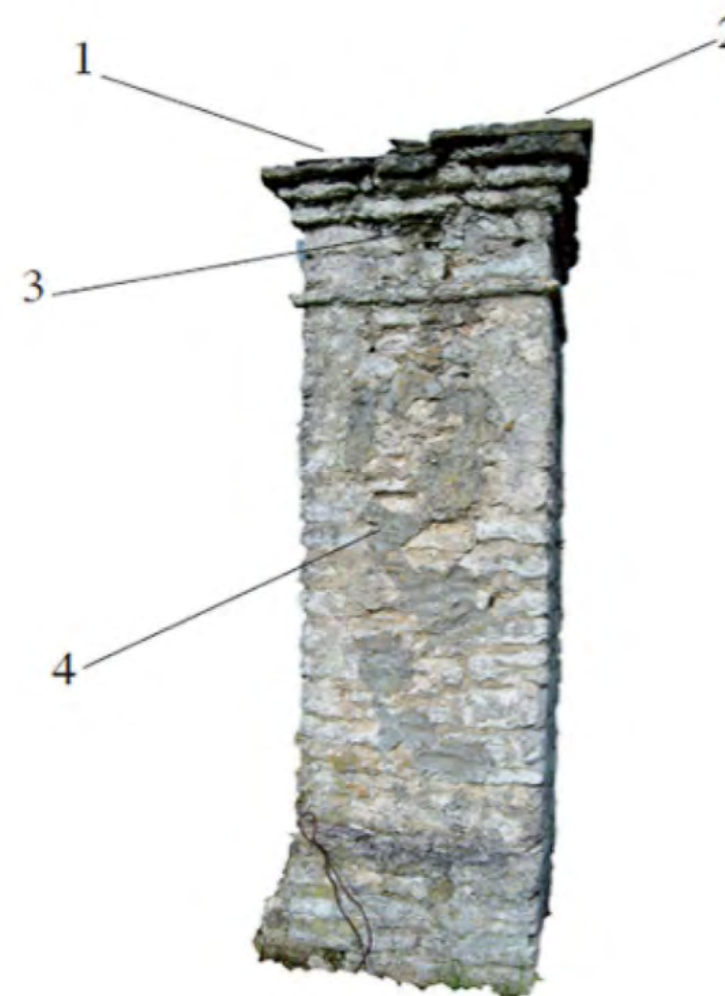

Figure 2.6. Gatepost A.

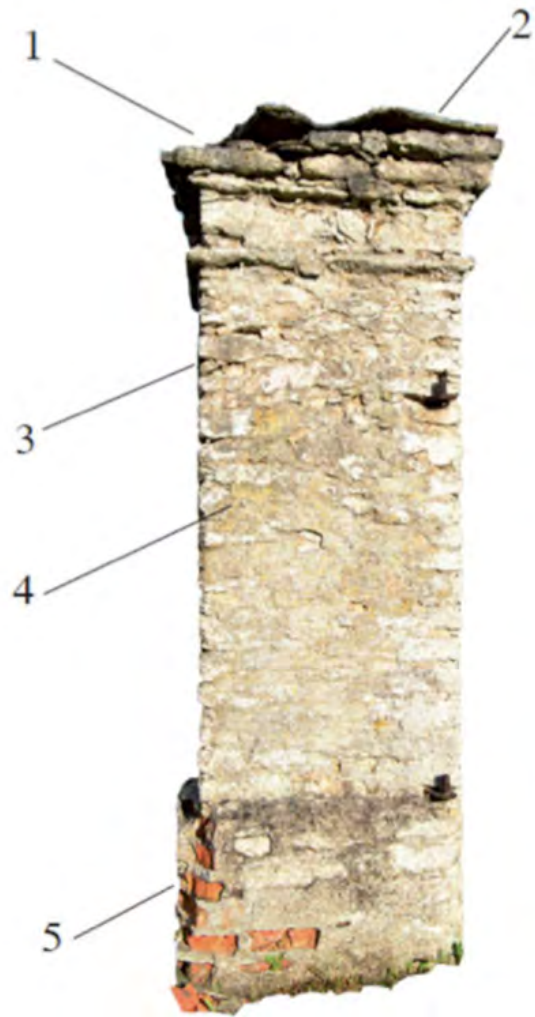

Figure 2.7. Gatepost B.

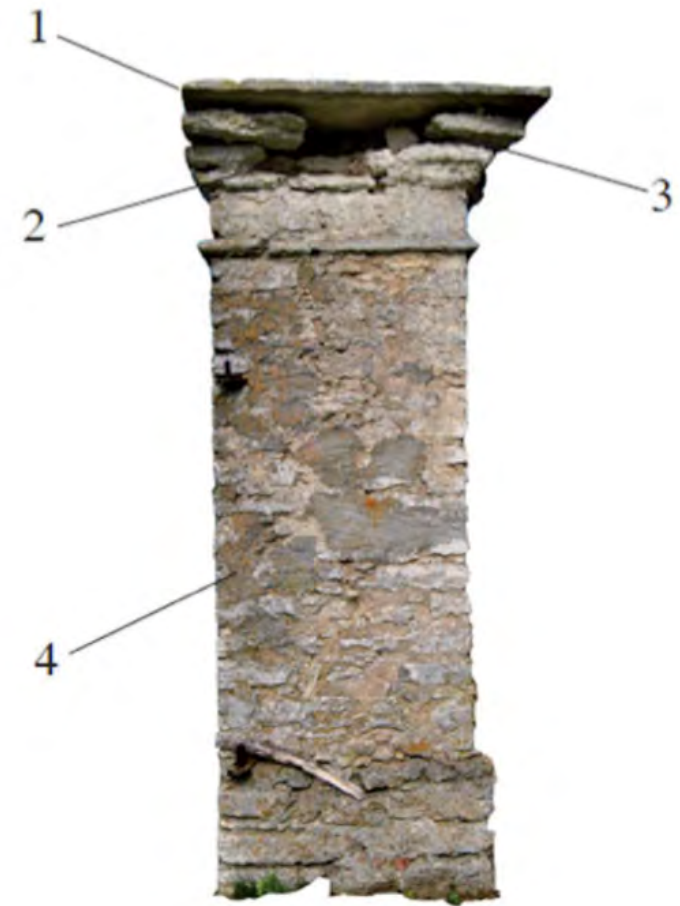

Figure 2.8. Gatepost C.



Figure 2.9. Estonian students working on gatepost C in the front; Finnish students in the middle, studying post B, and Swedish students busy with post A in the background.

2.4 HANDS-ON WORK ON GATEPOST A

2.4.1 USED TOOLS

We used several kinds of tools while working on the garden posts.

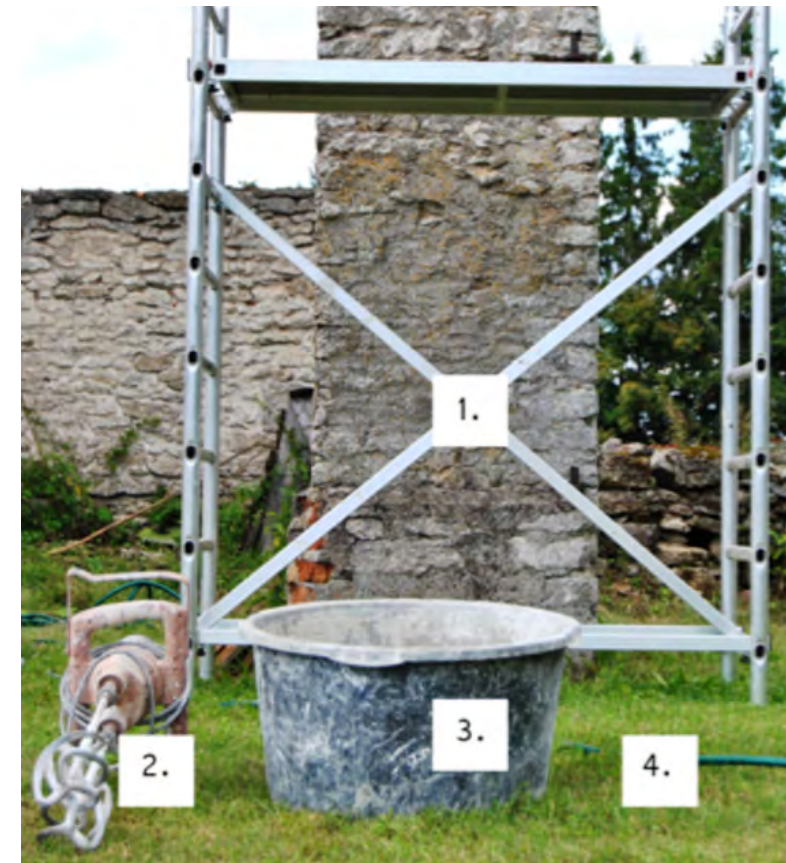

Figure 2.10. Tools: scaffolding (1)—used to reach the top of the posts; buckets (2)—used for mixing the mortar and lifting it up on the scaffolding; mortar mixer (3)—used for mixing the mortar in the bucket; water hose (4)—used for dampening and cleaning the surface of stones and cavities of the wall before applying the mortar. Water was of course needed in the mortar, too.



Figure 2.11. More tools: brushes (5)—used to wipe off sand and also to even out mortar on the sides of the posts; trowels (6)—used to apply the mortar onto the wall; waterproof gloves (7)—used when handling the mortar to prevent direct contact with lime; tape measures used for documentation.

2.4.2 REMOVAL OF PLASTER

Since the gateposts had been repaired with cement mortar this had to be removed. The removal of the cement mortar can sometimes be done with the use of a hammer and chisel. When removing the mortar it is important to work with great care. If large sheets are broken off, underlying softer materials can be seriously damaged.

Sometimes it is necessary to remove old mortar and layers of plaster where they have come loose from the underlying surface. New mortar or rendering can be applied only on a sound surface. Because of the bad condition of the top stones we had to

remove the topmost three layers of stones, add new stones between the old and lay them with new lime mortar.

2.4.3 MIXING MORTAR AND PLASTER

We mixed the mortar with the help of the first four tools above. When you mix the mortar you often have a recipe that tells you just how much water, stone and lime you should use.

During the documentation it can also be a good idea to take samples of the mortar and render to identify it, either by asking an experienced bricklayer or sending it off to a lab for examination. This will answer the question of what mix to use.



Figure 2.12. Samples of new mortar.

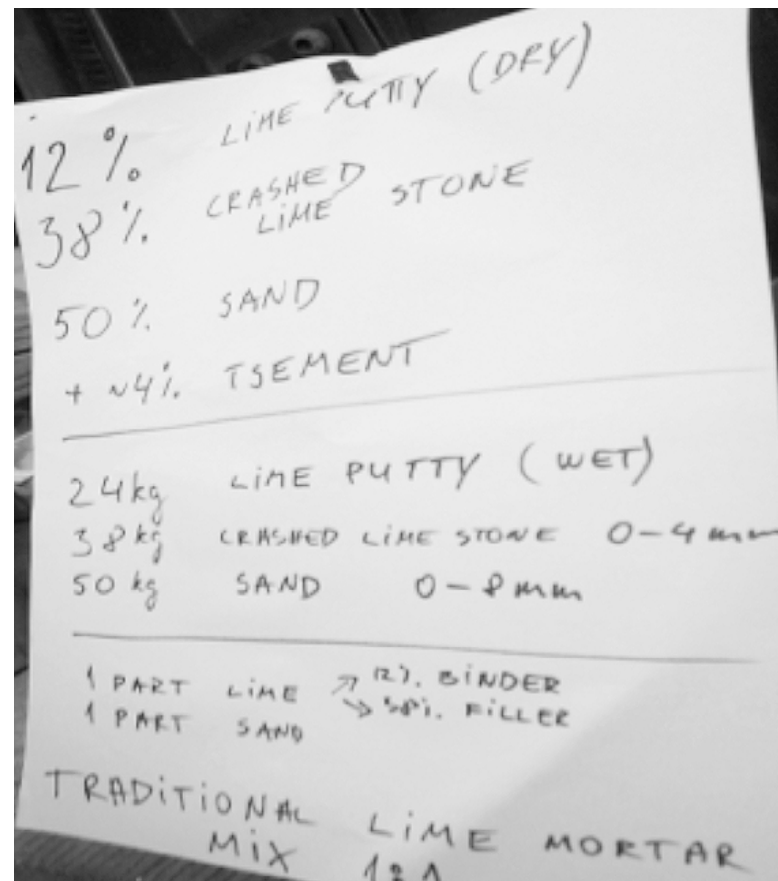

Figure 2.13. Recipes for mortars by T. Leis and K. Jürmann.

2.4.4 ADDING NEW STONES

After the removal of the old plaster and top stones we organized the stones on the ground in the same pattern as they were on the wall.



Figure 2.14. Dismantled stones from gatepost: top level (1), second layer (2)—middle part, and right—third layer from top, bottom part of gatepost profile (3).

We found suitable new stones in a nearby pile of rocks that probably once was a part of a wall. We puzzled the old and new stones together and laid them so that they together formed the old profile.

2.4.5 RENDERING

There are many different techniques for applying mortar and plasters. The technique depends on what the wall should look like when finished. To create a flat and straight surface it is necessary to apply several coats in order to fill deep pockets in the surface. To straighten the surface traditional tools like a plasterer's float and darby can be used. Before applying the mortar and render we need to activate the suction process in the stones by wetting them thoroughly. It is important to remember that the mortar must always be weaker than the stone (or brick), or the existing mortar.

On the garden posts at Seidla Manor we did not do any rendering, but left them with a rough surface instead. Cavities were filled roughly and the mortar was left to settle over night. On the next day excess mortar was washed and brushed away to match the surface with the rest of the weathered wall.



Figure 2.15. The broken flagstones on top of garden posts A and B had to be replaced with a topping of cement mortar because similar new stones were not available.



Figures 2.16–17. Finishing touches are being applied on gatepost C.

2.5 SOURCES

Written sources

Weismann, Adam & Bryce, Katy, (2008) *Using natural finishes—a step-by-step guide*, Green Books Ltd. ISBN 978-1-900322-16-4.

3. Maintenance of wood in historic buildings

Novia University of Applied Sciences: Mika Carling, Joni Helander, Kimmo Lahtinen, Fredrik Olin, Jonas Ranta-aho, Jonas Sahlberg, Peter Sjöström, Mikael Törnqvist, Staffan Wackström.

For the Finnish construction engineers and site managers the most useful information and exercises at Seidla Manor were about wood: how its condition can be evaluated and how it should be repaired. This part of the report describes not only the material but also the decay that might occur in it and how it ought to be prevented in a sustainable fashion.

3.1 DECAY IN TIMBER

3.1.1 INTRODUCTION TO WOOD

Wood is a heterogeneous, hygroscopic, cellular and anisotropic material. It is composed of cells. Every species has its own kind of cell structure. The walls of the cells are composed of cellulose (40 % – 50 %), hemicelluloses (15 % – 25 %) and impregnated with lignin (15 % – 30 %). Wood is classified as either softwood or hardwood. The names are misleading because hardwoods are not necessarily hard, and softwoods are not necessarily soft. For example balsa (hardwood) is softer than any commercial softwood. Conversely, for example yew (softwood) is harder than many hardwoods.

Softwood: 80 % of the construction timber in the world consists of softwood. Most of the softwoods are evergreen. The traditional centers of the production of softwood timber are in the Baltic Sea region, Russia, and North America. The most common species in the Baltic countries and Scandinavia are pine (*Pinus sylvestris*) and spruce (*Picea*). Larch (*Larix*) has lately become popular as it is resistant to rot but it does not grow naturally in Finland or Sweden.

Hardwood: the further north you go the more limited is the selection of hardwood in the forests. Most hardwoods are deciduous. In the northern parts of the Baltic Sea region birch (*Betula*), aspen (*Populus*), mountain ash (*Sorbus*) and alder (*Alnus*) grow wild, while oak (*Quercus robur*) is not found further than the southern tip of Finland and beech (*Fagus*) do not grow naturally further north than southern Sweden and Lithuania. These local hardwoods are better suited for furniture, carpentry, flooring, etc than for structural timber—apart from oak and beech which have been traditionally used for both purposes.

3.1.2 REASONS FOR DECAY IN TIMBER

All decay in timber is due to excess moisture in the material. The decay is caused by three agents: weather, fungi or wood boring beetles. The former causes wear through the combination of UV-radiation, heat and rain. The latter two feed on the nutrition in the wood, need oxygen and live in temperatures between 4 and 40°C.

The physical phenomena that transport the water into the constructions are diffusion, convection, capillary action, condensation and gravitation. If the wetted materials cannot dry, the constructions will start to decay. Examples of typical reasons for decay in structural timbers are discussed in the following.

Rain, snow, wind: Wind and weather will cause changes in the air pressure both inside and outside a building and accelerate the transport of water into the constructions. Driving rain or snow forces its way through cracks or faulty joints in walls and roofs.

Weathering: the surface of wood splits easily if it is wetted at first by rain and then quickly dried by the sun because the topmost cells then shrink faster than those behind. Continuous wetting and drying also cause a degradation of the lignin that binds the wood cells together. With time the cracks will get deeper and deeper, but the process is not faster than some 6 mm per 100 years. Weathered surfaces must not be mixed with fungal decay but rather compared to wrinkles on your face!

Condensation: when warm air (inside the house) collides with the cold air (outside the house) for example inside the wall, there may occur condensation which means that the vapor in the air condenses into liquid water. If the structure is too

airtight and the ventilation is not good enough the water will remain in the wall, roof or floor and provide fungi with a good breeding ground. Condensation occurs also on cold surfaces e.g. windows or cold water pipes and can cause local damage.

Leakage (gravitation): rain water may get into the construction trough for example a leaking roof, chimney or window. Water pipes, sewage pipes, dish washers and washing machines sometimes leak and cause serious problems.

Rising damp (capillary action): bad foundation technique or unwise landscaping can cause rising damp into walls and floors from the ground.

Humid indoor climate (diffusion, convection...): a family of 4 persons creates two buckets of water in the form of vapor per day into the air of their home through breathing, sweating, cooking, laundry and showering. This will find its way into the constructions of the home unless there is good ventilation.

3.1.3 FUNGAL DECAY

The fungi that cause trouble in buildings are of two kinds: wood rotting fungi which cause structural damage, and moulds which often cause health issues to inhabitants but generally have no effect on the structural qualities of timber.

The wood rotting fungi are divided into brown rot, soft rot and white rot. The first two destroy cellulose while white rot feeds on lignin. Brown rot is the main destroyer of structural timbers which crack to square pieces and turn brown when infested.

Serpula Lacrymans

Figure 3.1. Fruiting bodies of *Serpula lacrymans*.

The notorious *Serpula lacrymans* (true dry rot) belongs to the group of brown rots. It is found in all parts of the world, mainly inside buildings. It prefers temperatures around +20°C and can survive between +5 and +26°C. It needs oxygen but is sensitive to draught. A 30 – 40 % moisture content in wood is needed and the relative humidity of the air needs to be 95 – 98 %. *Serpula lacrymans* uses ions of calcium and iron (from plaster, rock wool, brick etc.) in the process of breaking down the wood. What makes it so dangerous is its capacity to transport water. Thus it can attack even dry wood and in favourable—or unfortunate—conditions it can destroy a house in a matter of months. The fruiting body smells good, rather like champignons.

Coniophora puteana

Another fungus in the group of brown rots is *Coniophora puteana* (cellar fungus which is one of the group wet rot), the second worst destroyer of structural timbers. It looks very much like *Serpula lacrymans*, but smells worse. This fungus will appear indoors and out of doors only in spots where there is enough moisture in the wood. Therefore

Coniophora puteana is easier to get rid of than *Serpula lacrymans*: remove the source of dampness!

The general rule in the fight against wood rotting fungi is to change their environmental conditions: ventilate, drop or increase temperature and make sure more moisture cannot enter the wood. If *Serpula lacrymans* is found it is important to investigate the whole building because the fungus can grow mycelia many meters long and its spores will spread all over. Remove fruiting bodies and all unsound timber. Destroy these immediately. Clean the interior from all spores (a deposit looks like cocoa powder). Whatever the fungus, you should remove the cause of the problem, repair the house and change its indoor climate permanently. Do not forget to ventilate spaces underneath ground floor!

Seidla Manor had several examples of brown rot. The fungi were not very active since the roof had been repaired and the wood work had dried together with the indoor climate.



Figure 3.2. Seidla Manor. Floor boards are cracked by fungi. The topmost layer of bricks and plaster has not allowed rising damp to evaporate from the underlying wooden construction.



Figure 3.3. Seidla Manor. Top left: brown rot; center: white rot and destruction by wood boring insects.

Moulds appear on any surfaces wherever there is excess humidity in the air and insufficient ventilation. A temperature between +30 and +35°C is most favourable for moulds but they withstand 0 – +55°C. Generally moulds are a result of careless construction or insufficient maintenance. Unfortunately both are very common today and the cost of repairs is hair-raisingly high.

Although moulds do not affect the stability of wooden structures their spores can cause serious health problems to people who live in rooms with infested structures: asthma, cough, head ache etc. The phenomenon is called *sick building syndrome*. Moulds also create an unpleasant smell that sticks to textiles and foodstuff.

3.1.4 WOOD-DESTROYING INSECTS IN THE BALTIC SEA REGION

With the climate change wood boring insects invade historic buildings further and further north. For instance on the Åland islands there is a newcomer called *Hylotrupes bajulus* (house longhorn, husbock, majasikk, tupajäärä) an extremely disastrous little creature.

Kalle Pilt, lecturer at Estonian University of Life Sciences, describes in his article Biodeterioration of Cultural Heritage in Estonia *Anobium Pertinax*, *Anobium Punctatum*, *Buprestis Haemorrhoidalis* and *Hylotrupes Bajulus* as the most harmful insects in Estonia. Finnish sources present yet another destructive beetle, *Hadrobregmus confusus*. In addition to beetle larvae that feed on wood the Black Carpenter Ant, *Componotus herculeanus*, can also cause structural failure.

Some beetles live only in the surface layers of wood while the larvae of others dig deep into the timber. Only the latter, which cause structural damage, are discussed here. In any case a population of insects indicates also fungal decay.

All wood boring beetles have a life cycle from egg to larvae, pupa and finally beetle. It is the larvae that cause damage. Some of them are known to live up to 20 years while other species have a cycle of only 2–3 years. They dig tunnels in the wood as they feed on it, and fill them with their excrement which looks like fine sawdust.

The only really effective, nonpoisonous and sustainable way of getting rid of these insects is to wrap the building up in a tight tent and heating it up to +60 – +70°C. Eight hours of such heat treatment will kill both insects and fungi. Unsound timber must of course be repaired, but if the life within the timber is gone the structure can be left in position as long as it can carry its load. In order to gain permanent improvement the indoor climate must then be changed in such a way that this flora and fauna cannot return.

Anobium punctatum

Figure 3.4. Anobium punctatum. Due to its small size this creature is a slow actor in the destruction business. This beetle disfigures antiquities but a day or two in a freezer or out of doors during cold winter days will kill it.

Copyright Dr. Uwe Noldt, Thünen-Institut, Hamburg (Germany).

FINNISH: tupajumi

SWEDISH: strimmig trägnagare

ESTONIAN: mööbli-toonesep

ENGLISH: Common Furniture Beetle

SPREADING: all of the Baltic Sea region (and beyond)

ADULT BEETLE: 3–4 mm long, striped, hunch backed

LARVAE: 4–5 mm long, c-shaped, white

FLIGHT HOLES: diameter 1–2 mm

LIFE CYCLE: 3–4 years

WOOD: both soft and hardwoods

DESIRED ENVIRONMENT: old damp houses

CLIMATE: cannot stand temperatures below zero, nor central heating

Hadrobregmus pertinax = Anobium pertinax

Figure 3.5. Hadrobregmus pertinax or Anobium pertinax, the insect that causes most trouble in buildings in our part of the world.

Copyright Dr. Uwe Noldt, Thünen-Institut, Hamburg (Germany).

FINNISH: kuolemankello

SWEDISH: envis trägnagare

ESTONIAN: suur-toonesep

SPREADING: all of the Baltic Sea region (and beyond)

ADULT BEETLE: 5–6 mm, black, yellow tassels at the back of the head

LARVAE: 5 mm, white

FLIGHT HOLES: diameter 2–3 mm

LIFE CYCLE: generally a couple of years

WOOD: softwood

FUNGI: the wood needs to be predigested by fungi

DESIRED ENVIRONMENT: damp

CLIMATE: survives severe winters

Hadrobregmus confusus

Figure 3.6. *Hadrobregmus confusus* is very much like *Hadrobregmus pertinax* but not so common in buildings.

FINNISH: hirsijumi

SWEDISH: nordlig trägnagare

SPREADING: northern parts of Sweden, South–West Finland...

ADULT BEETLE: 4–6 mm

LIFE CYCLE: 2–3 years

WOOD: only softwoods

FUNGI: the wood needs to be predigested by fungi

DESIRED ENVIRONMENT: damp, does not withstand central heating

CLIMATE: survives moderate temperatures below zero

LARVAE: 9 mm

FLIGHT HOLES: 3 mm

LIFE CYCLE: up to 10 years

WOOD: only hardwood

FUNGI: the wood needs to be predigested by fungi

Xestobium rufovillosum

Figure 3.7. *Xestobium rufovillosum*.

Copyright Dr. Uwe Noldt, Thünen–Institut, Hamburg (Germany).

FINNISH: rautio

SWEDISH: skäckig trägnagare

ESTONIAN: raudsepp

ENGLISH: Death Watch Beetle

SPREADING: All of the Baltic Sea region

ADULT BEETLE: 6–9 mm, brown

LARVAE: 9 mm

FLIGHT HOLES: 3 mm

LIFE CYCLE: up to 10 years

WOOD: only hardwood, oak in particular

FUNGI: the wood needs to be predigested by fungi

Hylotrupes bajulus

Figure 3.8. *Hylotrupes bajulus*, the most feared visitor in attic spaces. Its big and energetic larvae dig wide tunnels and due to its short life cycle the insect multiplies in large numbers.

Copyright Dr. Uwe Noldt, Thünen-Institut, Hamburg (Germany).

FINNISH: tupajäärä

SWEDISH: husbock

ESTONIAN: majasikk

ENGLISH: Old House Borer or House Longhorn

SPREADING: Åland islands in Finland, Estonian and Swedish islands, southern Sweden and beyond

ADULT BEETLE: 7–21 mm, black, two white stripes across the wings

LARVAE: 30–40 mm, light, black head

FLIGHT HOLES: oval, 6–10 mm

LIFE CYCLE: 2–3 years

WOOD: the sapwood of coniferous timber, both moist and dry

CLIMATE: sensitive to temperatures below zero

Buprestis haemorrhoidalis

Figure 3.9. *Buprestis haemorrhoidalis*. This beetle can be up to 20 mm long. It likes softwood (pine). The larvae live in dry wood, maybe on the sunny side of a building. Fairly rare in the northern part of the Baltic Sea region but more common the further south you go.

FINNISH: tumma jalokuoriainen

SWEDISH: bronspraktbagge

ESTONIAN: tähnikaardlane

SPREADING: all of the Baltic Sea region

ADULT BEETLE: 12–15 mm, slim, colour: metallic bronze

LARVAE: 35 mm

FLIGHT HOLES: oval 6–8 mm

LIFE CYCLE: 3 – 20 years

WOOD: softwoods

FUNGI: prefers dead decayed trees (in the forest)

DESIRED ENVIRONMENT: mainly forest in the north but also buildings further south

CLIMATE: withstands the Nordic climate

Camponotus herculeanus

Figure 3.10. Camponotus herculeanus usually builds nests in decaying wood both out of doors and inside timber structures. The damage is usually local but a big nest can cause failure of a structural member. The ant is 6–18 mm long and in one colony there may be thousands of individuals. They are difficult to get rid of but it helps if you find their queen and remove her.

FINNISH: hevostuorahainen

SWEDISH: hästmyra

ESTONIAN: taiga-hobusipelgas

ENGLISH: Black Carpenter Ant

SPREADING: all of the Baltic Sea region (including Lapland)

ADULT ANT: 6–18 mm

WOOD: prefers decaying wood

CLIMATE: not sensitive to cold

3.1.5 RECOMMENDED READING

Panu Kaila, 1997, *Talotohtori*, Porvoo, WSOY.

Rakennustieto *RT 08–10421*.

Rakennustieto *RT 08–10420*.

<http://www.woodculther.com/wp-content/uploads/2008/10/pilt1.pdf>

<http://www.woodculther.com/wp-content/uploads/2009/Kisternaya-Kozolov1.pdf>

<http://www.tuuma.net/artikkelit/Hyonteisvauriot.pdf>

<http://www.lfs-web.se/kallarsvamp.htm>

3.2 SUSTAINABLE PROTECTION AGAINST DECAY IN TIMBER

3.2.1 INTRODUCTION

When you work with timber, rule number one is to use dry timber in designs that will keep the wood dry. Other important factors to keep in mind when planning wooden constructions are:

- choose good timber;
- allow for shrinking and swelling of the material when designing details;
- protect your structures from sun;
- make sure the structures and surfaces can dry;
- choose a surface treatment that does not prevent diffusion.

In our climate there is no way of avoiding the wear and tear caused by rain, snow, sun and wind on facades. But there are long traditions of applying preservatives to weather boarding and wooden roofs for a longer life as well as decoration. The traditional materials and methods that are discussed here come from nature and can therefore be classified as sustainable in the true sense of the word. No harmful chemicals are needed!

3.2.2 LINSEED OIL IMPREGNATION

Linseed oil is used for treatment on wood products especially for wood in exposed environments. It is pressed from seeds of the linen plant and does not contain any toxic solvents or heavy metals. To enhance its qualities and speed up its drying it is boiled. This is linseed oil varnish, the binder in linseed oil paint. Linseed oil has been used for the protection of wood at least 2000 years but in the far north of Europe it did not become popular until the 18th century. At this time planed smooth weather boarding came into fashion and linseed oil paint was of course the only available surface treatment that could stick on this.

Clean the timber surface to get rid of paint or dirt. Make sure the wood is dry. You can use linseed oil varnish as a primer before painting with linseed oil paint. Alternatively you may apply as many coats of oil as are needed to fill all the pores of the wood. The oil is edible and therefore well suited e.g. for wooden utensils, table tops and cutting boards let alone carpentry in buildings.

3.2.3 LINSEED OIL PAINT

In its simplest form linseed oil paint is a mixture of earth pigments and linseed oil. Many experiments have been made over the centuries to make it more durable, thicker or thinner or faster to dry, and therefore there are often some additives in old layers of paint. The same applies to modern commercial linseed oil paints. True linseed oil paint takes a few days to dry. It has a hardwearing and durable surface that newer flakes off, it just fades away. It can last on a façade for some 30 years before any repainting is needed.

Apply the paint in thin layers. This can be done time after time without scraping away more than loose patches of the old paintwork. That is a great advantage when you maintain an old façade or boat.

3.2.4 WOOD TAR

Wood tar, which is produced from the wood and roots of pine through distillation in a tar kiln, has a long history. As long as ships and boats were made of wood this was the most important timber preservative in ship yards, but it was used in exposed parts of buildings as well, wooden roofs in particular. It was the most important export article in Finland in the 17th and 18th centuries. Of course, the production of tar was extensive also in Sweden, Estonia and other countries with a large supply of pine wood.

Wood tar is considered a superb preservative and since it is a true product of nature—made from wood itself—it can be considered sustainable. The oily tar penetrates into the cell structure of wood and after several applications it forms a skin over the surface. Tar also contains several substances that destroy such microbes that live on and in wood.

Wood tar can be mixed with linseed oil to make a paint that dries faster than tar. Pine turpentine will make the mixture thinner still. Mix e.g. 1/3 of each and add some earth pigment to attain a wonderfully scented traditional paint for weather boarding, terraces, garden furniture—and of course, your wooden boat! Repeat the treatment until the wood is fully impregnated. The fishermen of Roslagen along the coast north of Stockholm have a long tradition of treating their boats like this. This is why Swedes call the mixture *Roslag's mahogany*.

3.2.5 CHARRING

An ancient way to protect wood from decay is to burn its surface. The carbonized skin will protect the inner parts from attack by fungi or insects. This is a good method for e.g. fence posts and other timbers that are in direct contact with the ground.

3.2.6 HEAT TREATMENT

A modern way of protecting wood is by heat treatment. The precut pieces are heated up to about 200°C while the process is regulated by the use of steam. No chemicals are used. The wood attains a darker brown colour than is natural, it becomes slightly brittle but above all, it becomes resistant to fungi.

3.2.7 NATURAL IMPREGNATION OF PINE

If you need very durable timber it is advisable to manipulate the living trees so that a natural impregnation process fills their pores with resins. The ancient method, which was common practice still a hundred years ago, is to simply peel off ca 1m long stripes of the bark of fully grown, good quality pine trees and leave them standing for a few years before harvesting. The resinous material is perfect for windows, flashings and other exposed parts on facades. This is also how trees could be pretreated before they were cut for tar production.

3.2.8 RECOMMENDED LITERATURE

Panu Kaila, 1997, *Talotohtori*, Porvoo, WSOY.

Panu Kaila, 2000, *Kevät toi maalarin*, Jyväskylä, Gummerus.

3.3 METHODS FOR DIAGNOSING THE HEALTH OF TIMBER STRUCTURES

3.3.1 INTRODUCTION

The inspection of a timber structure is difficult without breaking it because the damage occurs inside the material. In order to analyze a building or structure closely, parts of it should be removed and transported to a laboratory but this kind of approach is often impossible, especially in buildings of cultural heritage.

The most important factor that affects the durability of wood is bio-deterioration, i.e. timber decaying fungi and wood-destroying insects, such as ants and wood boring beetles.

The most valuable tools for non-destructive examination of historic buildings in general are an open mind, good eyes, and a good sense of smell. And of course, before starting repair work on old buildings, a good knowledge and understanding of both original construction methods and materials is very important.

Knocking on the wood to hear if it rings is a good technique: if it does not ring but sounds muffled, there is most likely something wrong with it. To gain more exact knowledge there are many modern tools for examining timber structures without harming them. These must be recognized as a complement to—not a replacement for—that knowledge. A good tool can help you gather the necessary information for selecting the most appropriate and cost-effective course of action in the planning of a repair. We had a unique opportunity to test some of these at Seidla Manor.

3.3.2 MEASURING DEVICES USED AT SEIDLA MANOR

Endoscope: An endoscope is a tool which helps you investigate areas inaccessible to the naked eye. There is a whole range of different endoscopes, smaller and bigger, cheap ones and expensive ones. Simple bore scopes consist of a light source, a thin rigid tube with built-in optics and an eye-piece. By drilling a small hole, usually less than 12 mm, and inserting the tube, it is possible to inspect voids under floors and behind paneling. Any hidden problems such as fungal growth can in theory be found but to understand the transmitted images requires experience.

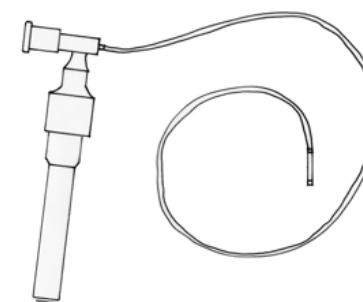

Figure 3.11. An endoscope. The scope may be attached either to a flexible or a rigid tube.



Figure 3.12. Some fungi could be detected underneath the floor boards of the upper hall at Seidla Manor.

Micro-drilling: micro-drilling is the best technique available today for investigating timber. A 1 mm drill probe which is attached to a computer penetrates up to 200 mm into the timber and records faults by measuring the speed of penetration. The extent of decay and its position can thus be determined. The information is extremely valuable for engineers who need to calculate the load bearing capacity of old structural timbers and decide on methods of repair.



Figure 3.13. Micro drilling apparatus.



Figures 3.14. One student is drilling into a roof truss while the other is learning to interpret the transmitted information on the computer. Prof. Kalle Pilt, lecturer at Estonian University of life Sciences, (far right) is explaining the curves on his computer screen.

Pilodyn: Pilodyn is an instrument that is easy to use for testing wood. The Pilodyn operates by shooting a blunt steel pin (\varnothing 2,5 mm or \varnothing 2,0 mm) into wood by an exact amount of energy. The penetration depth is read on a scale.

The Pilodyn is used on many different wooden objects for testing the rate of decay as well as wood quality in general, e.g. of railway sleepers, structural timbers in houses, wooden bridges, fence poles...



Figures 3.15–16. The Pilodyn was tested on timber with various degrees of decay.

3.3.3 OTHER USEFUL DEVICES FOR THE STUDY OF TIMBERS AND WOODEN DETAILS IN HISTORIC SETTINGS

Moisture measurement: Electrical resistance meters do not give information about the moisture within the timber because they can only measure the moisture content on, or just below the surface of timber. Old surface treatments can also change the resistivity of the timber and give misleading results. Other factors such as foils within the structure, high carbon content of materials, and condensation can give false results. It is important to measure deeper inside a structure to get a reliable result. This can be done by inserting small sensors into holes that are drilled in the timber.

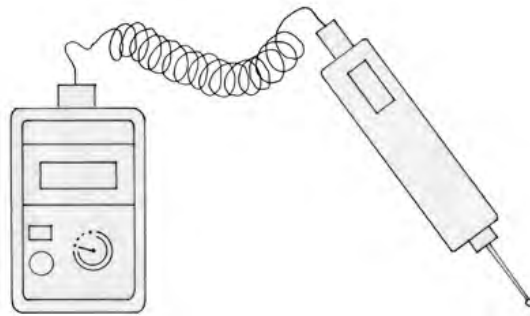

Figure 3.17. Electronic moisture meter.

Infra-red thermography: In addition to discovering location of heat loss an infra red camera can reveal:

- structural timber frames behind render, weather-boarding plaster, etc
- structural joints, infilled openings, etc behind render on masonry walls
- bond failure and moisture ingress in renders, pargetting and harling
- lintels, structural failures, snapped headers, etc in brickwork
- variations in moisture levels.

The camera is easy to use and the results are fairly easy to interpret for someone who is familiar with structural design.

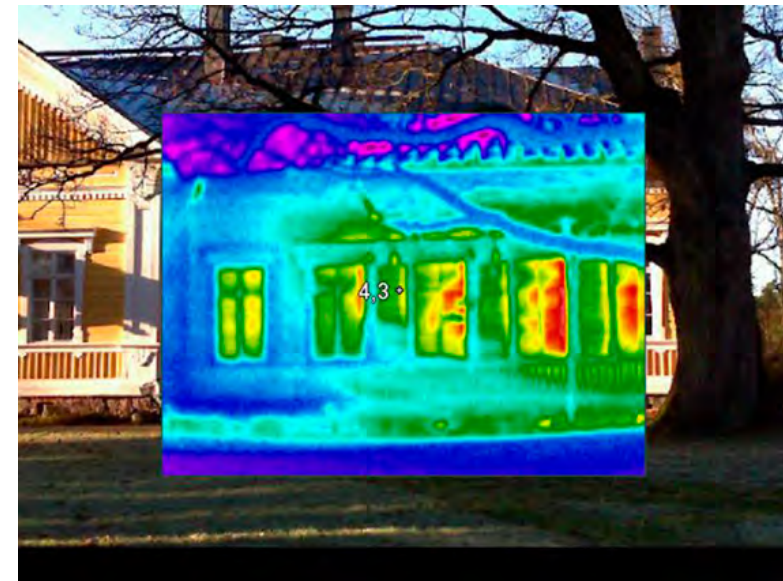

Figure 3.18. Example of an infra-red photo.

3.3.4 SOURCES

<http://www.woodculther.com/wp-content/uploads/2009/09/Pilt.pdf>

<http://www.buildingconservation.com/articles/nondestr/nondestr.htm>

<http://www.krsis.dk/201-pilodyn.htm>

Inneklimat och brandsäkerhet i fem finländska kyrkor:

<http://publications.theseus.fi/handle/10024/26696>

3.4 REPAIRING OF STRUCTURAL TIMBERS**3.4.1 INTRODUCTION**

When fungi and insect damage occur in timber it usually means a lot of work to fix the damaged parts. It is recommended you replace the damaged parts with new timber parts but sometimes it is necessary to use steel reinforcement and sometimes even epoxy resin. In any case the replacing of timber requires expert knowledge and highly skilled methods. Often the repairs are time-consuming and cannot be done without the removal of floorboards and ceilings.

3.4.2 PREPARING THE LOGS

To build and repair parts of a beam which have been destroyed or damaged you have to get some good size timber. Of course the dimensions of the original have to be matched. In the northern hemisphere structural timbers have in general been made of coniferous trees, spruce and pine. These have straight trunks and the resin in the tree is a good impregnating agent against decay. In countries where these varieties of trees are not so common oak and beech are used. The best time to fell a tree in the northern hemisphere is between December and March because at this point the absolute humidity in the air is generally low and the flow of water inside the tree itself is insignificant. The low temperature in this season prevents insects and fungi from attacking the material.

After the trees have been transported out of the forest the logs are formed to the desired dimension. There are different methods to make the logs. The easiest method is to saw the trunks to the right dimension with a circular saw or a band saw. Traditional methods of manpower may require special tools, for example a carving axe. It is essential to remember that the log is going to shrink between 4–8% as it dries. Therefore it is also essential to allow the timber to dry at least two years before it is used for repair work.

A non-load bearing timber is easier to replace because you don't have to start

by calculating how much tension or pressure it should hold. Replacing of a load bearing horizontal timber is more critical and requires professional knowledge. It is recommended, where possible, to make a joint in a place where the beam or truss leans on a load bearing wall or column.

3.4.3 DIFFERENT TYPES OF SPLICES

There are many different types of splices. (American English and British English use different terminology here). You choose the splices according to where you place the new part of the beam. You also have to know if it is to withhold pressure or tension.

1. Simply lapped and bolted splice;
2. locked and lapped splice;
3. shouldered splice;
4. lapped splice with wedges to tighten;
5. shouldered splice; or,
6. dovetail splice.

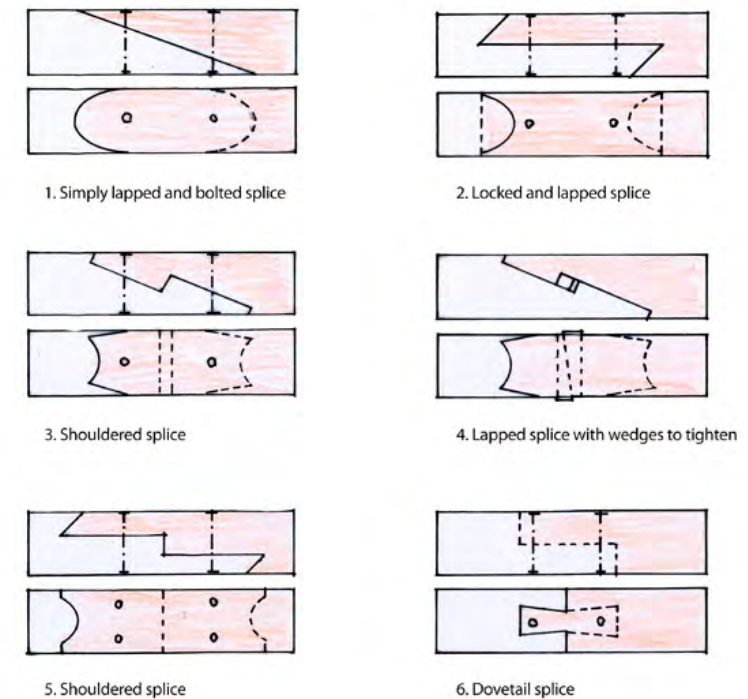

Figures 3.19, 1–6. The shouldered splices above are good examples of joints to use when repairing load bearing beams. Locked and lapped splice can be used when repairing pillars.

3.4.4 REPAIRS WITH STEEL AND EPOXY RESIN

Very often fungal decay occurs where the structural timbers are in contact with masonry. Therefore you often have to replace a whole joint. New and old parts can be joined by using disguised steel or fibre reinforcement bars. First the structure must be supported and then the rotten parts can be removed and replaced.

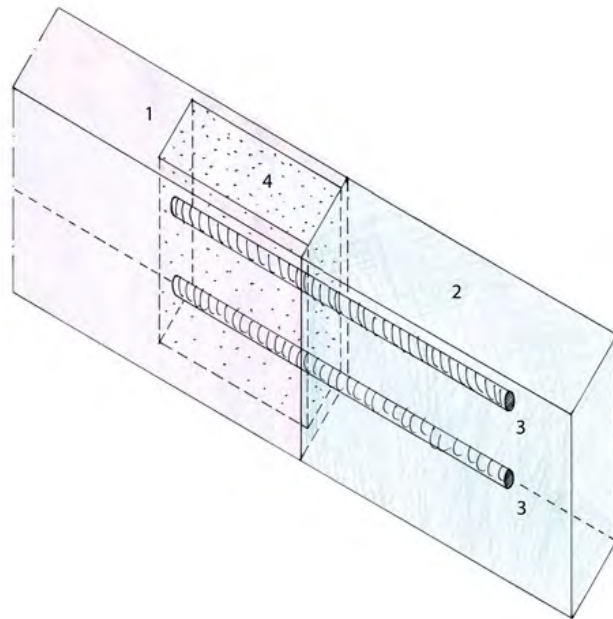

Figure 3.20. In this illustration the timber is reinforced with steel and then a resin mixture is poured into the joint between old and new parts:

1. the end of sound old beam or joist is hollowed to make a form for epoxy resin.
2. replacement of decayed section of timber.
3. steel reinforcement bars attached to (2).
4. resin.

Examples of how to repair rotten parts of a beam can be found on the web pages of expert firms that specialize in timber repairs.

In conservation work the original building methods and materials of the site should be used. Only if these methods prove impossible you can take to other methods. Some architects think that repairing timbers with visible steel plates is a more honest way of repairing constructions than trying to conceal the patching. In any case, the detailing requires both good designing and good craftsmanship.

We must also keep in mind that a rigid joint can cause problems because it does not move with the rest of the construction.

3.4.5 REPAIRING LOG CONSTRUCTIONS

The lower logs in old log wall constructions are often susceptible to fungal decay due to rising damp. If only the outer part of the log is rotten you can simply cut out that part and replace it. It is very important to remember that you should always shape the joint between the old and the new part in such way that water does not get to flow in to the construction.

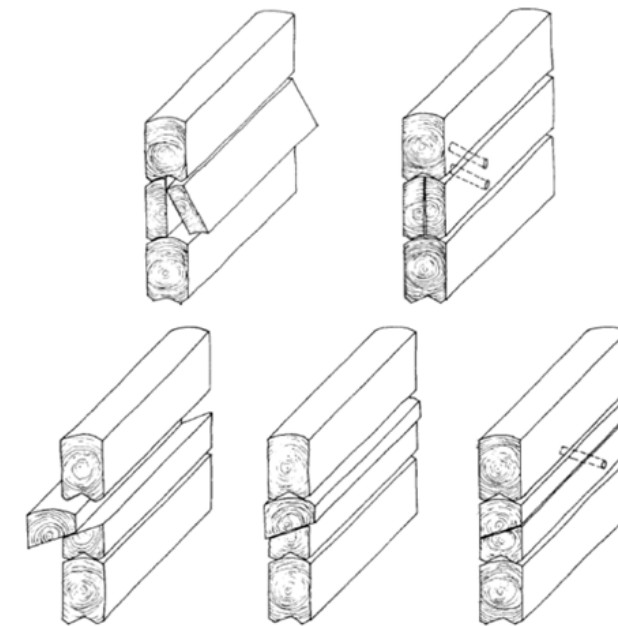

Figure 3.21. By replacing only half the log the rest of the structure can be left untouched. When the new part is in place you should secure it with wooden pegs. (<http://www.nba.fi/fi/File/109/korjauskortti-16.pdf>)

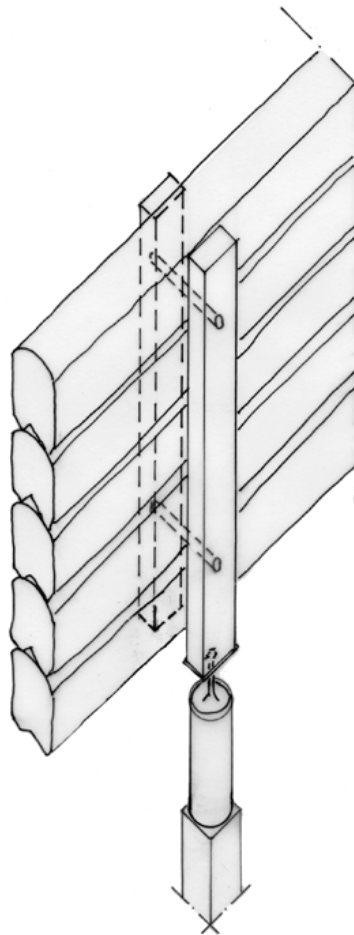

Figure 3.22. Hydraulic jacks are used when sill logs must be replaced and the whole house needs to be lifted. The jacks are placed at strategic points so that the structure can be kept level and secure while carpenters access the structure from the side.

3.4.6 WOODWORK EXERCISE AT SEIDLA MANOR

In Seidla we had the chance to try to make a hooked scarf joint or a lapped splice with wedges to lock it. Here are some pictures of our work.

We did not actually repair any of the beams in Seidla Manor—but we got an excellent representation of how beams could be repaired by two Estonian experts, Tarmo Tammekivi and Andres Ansper. Thank you both, indeed.



Figure 3.23. Andres Ansper is showing us how to design and draw the joint.



Figure 3.24. Here we are cutting out the splice with a chainsaw. Tarmo Tammekivi (*far right*) is supervising the amateurs.



Figure 3.25. Here we learn how to hew the timber with an axe.



Figure 3.26. Then we learn how to carve with a chisel.

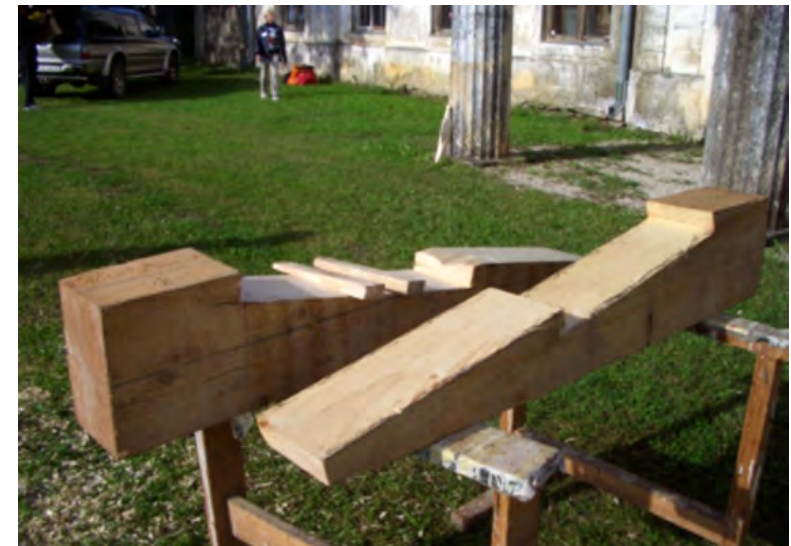

Figure 3.27. Here are the two finished pieces.



Figure 3.28. Finally we put the pieces together and secure the lock made of two wedges.



Figure 3.29. Here is a beam joint that withstands tension.

3.4.7 DRAWING

We took two logs that were of the same length, width and height. Firstly it is very important to draw very exact lines on the two logs, so that they mirror each other. In other words when the two logs are done, one can be turned upside down and placed on the other, and they are an exact match. There were several assisting lines drawn before the actual lines of the beams could be drawn. It was important that there would be a square hole in the middle of the new joint, where a double key piece would fit tightly. The shape of the beams can be seen on the pictures below.

Sawing and rough shaping: when the drawing was done, it was time to saw the two beams closer to the actual shape they needed to become. At first it was done by chain saw. It was important to saw so that the lines that showed the shape of the beam would not be crossed. Closer to the center of the beam we only needed to saw a few centimeters, but at the edge of the beam we could saw almost all the way. After sawing there were many vertical saw lines from the top of the beam to a certain height, depending on if it was at the edge of the beam or the center. The parts between these vertical sawing lines were removed by pounding them with an ax. Because the pieces were only maybe 5 cm wide they could be pounded loose without much effort. After the pieces from both of the beams were pounded loose, you could already see a rough shape of the two beams and how they would fit each other.

Grinding and fine shaping: now we were left with a large surface that needed to be fine shaped, so that the two beams could be placed on each other. At first the shaping work was done by chisel and hammer, simply pounding pieces away without crossing the lines drawn in the beginning. When the wood started to take a finer form the work continued with the help of a plane. With the plane, the area that was to meet with the corresponding area of the other beam, was made smooth and nice so the two beams could meet exactly.

The key: the key ensured that the beams would not and could not separate. If you look from the side of the beam the wedge hole is square. When the two wedges are pounded in place from separate sides they secure the entire construction as planned.



Figure 3.30. The finished joint.

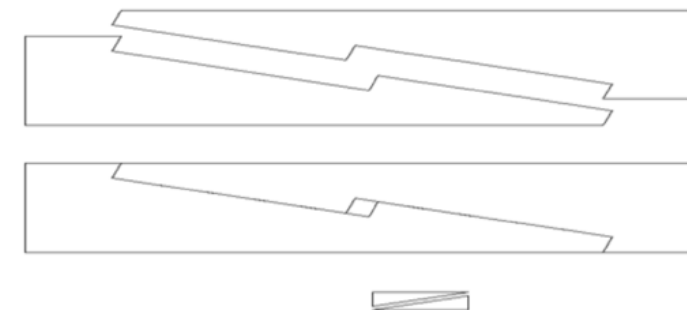

Figure 3.31. A model drawing of a beam and its key-piece.

3.4.8 LITERATURE

- Curatio, Björkfeldtin talo, Parainen, työmaaraaportti. <http://www.curatio.parnet.fi/Bjorkfeldtin%20talo,%20Parainen.%20Tyomaaraaportti.pdf>. 13.10.2010
- Museovirasto, Hirsitalon rungon korjaus. <http://www.nba.fi/tiedostot/e1d5b07e.pdf>. 13.10.2010
- B. Allan Mackie, The owner-built log house, Firefly books Ltd 2001. 13.10.2010
- Timberwise, Timber engineering– Replacing rotten timber using resin repairs. <http://www.timberwise.co.uk/our-services/structural-repair/timber-engineering/>
http://www.timberwise.co.uk/wpcontent/uploads/2009/12/timber_engineering_solutions_leaflet2.pdf
<http://www.raol.roiakk.fi/>. 14.10.2010
- Log building tools. http://www.hirspek.fi/seppa_eng.html. 14.10.2010
- Marlowe Restorations LLC. <http://www.marlowerestorations.com/timberrepair.html>. 7.11.2010

3.5 EXAMPLES OF WOOD REPAIRS AT SEIDLA MANOR**3.5.1 WINDOWS**

All the windows at Seidla Manor were in fairly poor condition. Because the time was limited we concentrated our efforts on the casements of six roof lights. The process of our repair work is described below.



Figure 3.32. A typical window at Seidla Manor. Much work will be required.

Inspection: the windows were removed from their frames and taken outside and placed on worktables.

We discovered that no putty had been used between glass and casement nor between glass and glazing beads. At first the old decayed glazing beads around the glasses had to be removed. This was done carefully with a knife or a chisel. It had to be done with some precision so that neither casement nor glass would suffer any harm. The small nails were either removed by pliers or they could be pounded further in. When beads and nails were out the glasses could be removed. Casements and glasses were marked so that they could later be reunited.



Figure 3.33. A glazing bead is being removed.

The casement and the pegs: we started with removing the old pegs that hold the casement joints together. The pegs were removed by simple use of a nail and hammer, and some careful pounding so that the casement would not break. New pegs were carved from new wood, so that they would hold another 50 years. These were hammered through the existing holes. Now that the casement was stable again it had to be repaired.

All surfaces were sandpapered clean from loose paint and decayed tissue. At the same time the parts of the new pegs that stood out were ground as well. The idea is not to make the wood perfectly smooth, unless you want that, but just to grind so much that all the parts that are old and decayed will be removed.



Figure 3.34. A new peg is being pounded gently into the casement of a window.



Figure 3.35. Sandpapering was quite easy as there was only one coat of paint to be removed and the wood was mostly in good condition.

Finishing: when the grinding part was over it was time to prime the surfaces with linseed oil. A few days later we could start reinstalling the glasses. The casement was placed on the worktable so that the inside of the window was down. A 1–2 mm thick bed of putty was pressed in the glazing groove. Then the glasses were reset on the bed of putty and pressed tight so that no air was left between glass and putty. When the glasses were in position small pieces of wood were pressed around them to keep them from sliding sideways. Next they were secured with the help of some small nails (preferably glazing points) which press the glass down as they are gently hammered into the surrounding wood. Finally the putty is inserted and trimmed with a putty knife so that it covers the nails and the groove (which is visible through the glass). Because traditional putty has the same binding agent as the paint, i.e. linseed oil, it can be painted as soon as it has been applied. Indeed, it is very important to paint it within a week or so to save it from drying and cracking.



Figure 3.36. Nails are being inserted. The small hammer is wrapped in masking tape to avoid scratches on the glass.

Decayed parts: there were windows with parts that had decayed so badly that they had to be removed. This was done by sawing the decayed piece away diagonally from the window. Then it was carved by chisel and replaced with a new piece of wood, sawed diagonally as well, and glued in its place. The new piece of wood was not carved or formed like the window before gluing. It would be done after the glue had dried, and the new piece of wood could be formed to match the surrounding shapes of the window.



Figure 3.37. A new piece of wood has replaced an old decayed part.



Figure 3.38. The new patch of the weather moulding is being shaped to match the old parts.

3.5.2 CORNICES

The following instructions are for replacing or repairing an indoor cornice with a timber frame and a plaster finish. The adjacent construction parts are the walls and the ceiling of the given room.

Constructions: the frame can be built either by fixing a plank or a board directly to the adjacent constructions or by using a wooden console that is attached to the adjacent constructions, after which boards are fixed to the console. The latter will obviously allow you to make a cornice of greater dimensions than the former.

Preparations, schedule: the building of a cornice should not take place until the adjacent ceiling and wall constructions are finished. If either the wall or the ceiling needs restoration and/or replacement of structural parts one should finish those tasks first. However, the final layer of plaster, or possible wallpaper or paint, cannot be applied until after the cornice. If there are constructions that must not be harmed in the room where the work is done, these constructions must be protected or if possible removed during the work.

Timberwork: the timber used for a cornice which will be plastered should have a harsh surface rather than a smooth one. This improves the adherence of the plaster. The wood must of course not be rotten but otherwise you can use any wood available.

If a complete reconstruction is to be done, the starting situation for the cornice work should be the following:

- The walls (at least the upper parts of them) and the ceiling need no further repair or replacement of construction parts.
- Loose parts of the walls and old plaster are removed.
- Ensure that fixing of the new cornice to the walls and the ceiling is possible with appropriate methods depending on the construction materials used for each construction part.



Figure 3.39. In some of the rooms at Seidla Manor there was neither ceiling nor cornice. Everything needs to be rebuilt.

108

If only partial replacement is needed the following issues should also be taken into consideration: All old structural parts must be properly fixed, anything that easily falls off when lightly hit with a hammer will most likely not stay in its place for long unless the fixing is improved.



Figure 3.40. Plaster is removed from the ceiling and partially from the cornice. The ceiling needs insulation and the attic floor is missing, too. However, the timber frame of the cornice is most likely in good condition. The shape of the old cornice is possible to replicate.

If only the finishing coat is to be renewed dust and fat must be removed from the surfaces before treatment.

109



Figure 3.41. In some of the rooms at Seidla only the paintwork is damaged otherwise the cornice is in good condition.



Figure 3.42. Consoles for the upper hall cornice are being made.



Figure 3.43. In the upper hall: new consoles are in place and planks are being attached to these. We finished the woodwork for the cornice along one wall.



Figure 3.44. Reconstructing a cornice in one of the badly damaged rooms on the upper level.



Figure 3.45. Well done! Only another few hundred meters to go... the two engineers are waiting for more instructions from the Master of Seidla, supervisor of all the work we performed.

Plastering: when preparatory work is done, form the consoles to the desired shape using appropriate tools, e.g. a jigsaw. Fix the framework of the cornice to the walls and the ceiling. Attach a reed web, or a plastic mesh, using staples or nails to the wooden surfaces that are to be plastered. Mix the plaster according to the original recipe and start applying this to the framework of the cornice. The plaster can be applied by throwing, pressing or spraying. The shaping of the cornice starts after the first layer of plaster has been applied. The shaping is done by dragging a stencil made of plywood, which is cut to the desired shape, along steering planks on the wall and the ceiling. The stencil can be reinforced with a metal plate. The shaping is done in as many layers as required. Do not apply too much plaster at a time.



Figure 3.46. We were given a chance to try the traditional method of plastering the reconstructed cornice. This job is definitely something for experts!

Appendix

COURSE PROGRAMME 5.–11.9.2010 AT SEIDLA MANOR, ESTONIA

<i>Time</i>	<i>Remarks</i>	
Day 1 / September 5, 2010		
10:00	The Swedish students arrive in Tallinn (D–Terminal)	Parking minibuses in the courtyard of the Department of Cultural Heritage and Conservation (EAA), Nunne 11, Tallinn
11:00	Excursion in Tallinn guided by Prof. Joakim Hansson	Lunch, exchanging money etc.
13:30	The Finnish students arrive in Tallinn (A–Terminal)	Parking minibuses in the courtyard of the Department of Cultural Heritage and Conservation, EAA, Nunne 11, Tallinn
14:00	Excursion in Old Tallinn guided by Prof. Joakim Hansson both for the Swedish and Finnish students	Quick meal, exchanging money etc.
17:00	Driving out of the city to accommodation place in Jäneda manor	A stop at a supermarket to buy food, drinks etc.
19:00	Check–in at Jäneda manor guesthouse	Jäneda estate has been the heart of the Jäneda village for centuries. The latest manor building was built by Johan von Beckendorff in 1915. The lady of the manor Maria Zakrevskaja–Beckendorff has written the estate in the history through her colourful life. She had connections with the attempted murder of Lenin, life with such writers of worldwide magnitude as Maxim Gorki and Herbert Georges Wells. In the evenings we can gather in the fireplace room with a spacious balcony. Internet www.janedaturism.ee
19:30	Welcome dinner in the Stable of Black Stallion tavern	The Stable of Black Stallion was built for horses of Jäneda estate in 1888 and now has become a popular tavern. Amateur and professional artists provide tourists and other interested people with folklore and music programmes. Spacious rooms allow organization of gatherings, formal lunches and dinners up to 340 guests but in Sunday evening the place is reserved for our group only. Getting acquainted, discussing the activities during the workshop, building up international working teams

Day 2 / September 6, 2010		
7:45	<i>Breakfast</i>	
8:15	Departure from Jäneda to Seidla manor	
9:00	Looking around at Seidla manor guided by Mati Raal, Estonian Academy of Arts	
10:00	Lecture about documentation and investigation practice in Estonia. Introduction to the following hands–on work by Maris Suits, Estonian Academy of Arts	
10:30	Lecture 'How fix old windows' by Kirsti Horn, Novia University of Applied Sciences	
11:30	Hands–on work: Inventory of Seidla manor's windows	Hands–on work: In Seidla manor there are windows of three different ages. The aim is to record all of the windows of the main building, determine the age, type, documentate on plans and views. Each team will carry a thorough research of one type of window (measuring, taking profiles, paint samples, inventorying accessories, making sketches etc) and make a proposal for fixing/replacing. Attempt to fix at least one window. Estonian tutors: Mati Raal, Kalle Pilt, Maris Suits
14:00	<i>Lunch</i>	Lunch will be provided to Seidla manor
15:00–18:00	Hands–on work continues	
18:15	Visit to Seidla windmill	The 18th century Seidla windmill is one of the few Dutch type windmills in the cultural history of Estonia that has preserved with all original fittings and in its original function. Seidla windmill also represents the typology of manor windmills as it is located a little distance from the centre of the manor on a visible hill. The number of such preserved windmills in manor ensembles all over Estonia is less than five. Seidla windmill is the first renovated authentic Dutch windmill in Estonia and protected as a national monument. The windmill is a fully functional corn mill. Internet www.seidlatuulik.ee

STUDENTS' WORK

Day 3 / September 7, 2010		
7:45	<i>Breakfast</i>	
8:15	Departure from Jäneda to Seidla manor	
9:00	Hands-on work on Seidla manor windows continues	
12:00	Lecture 'In the middle of nowhere? Estonian manors—seven centuries of light and dark' by Juhan Maiste, professor of Tartu University	
14:00	<i>Lunch</i>	
15:00	Preparing for hands-on work of mural conservation	Examining the condition of Seidla manor's courtyard wall, making conservation proposals
15:30–18:00	Hands-on work of mural conservation	Estonian tutors: Kermo Jürmann, Taavi Leis, Mati Raal, Kalle Pilt, and Maris Suits
18:30	Visit to Albu manor. Guided tour. Restoration of ceiling paintings by Vaike Vaher, master student, EAA.	Albu manor is situated 8,2 km from Seidla
Day 4 / September 8, 2010		
7:45	<i>Breakfast</i>	
8:15	Departure from Jäneda to Seidla manor	
9:00	Hands-on work of mural conservation continues	
12:00	Lecture 'Swedish, Finnish and Estonian manors—similarities and differences through ages' by Prof. Joakim Hansson, Gotland University	
14:00	<i>Lunch</i>	
15:00–17:45	Hands-on work of mural conservation continues	
18:00	Visit to Roosna–Alliku manor	Roosna–Alliku manor is situated 8,5 km from Seidla
19:30	Sauna–Bastu evening at Jäneda guesthouse	
Day 5 / September 9, 2010		
7:45	<i>Breakfast</i>	
8:15	Departure from Jäneda to Seidla manor	

RESTORATION CRAFTS—SUSTAINABLE HERITAGE REPORT NO. 2

9:00	Lecture 'Non-destructive methods of determination the condition of timber constructions' by Kalle Pilt, Estonian University of Life Sciences	
10:30	Parallel hands-on work: Non-destructive evaluation of timber constructions (attic, ceilings, floors) of Seidla manor, tutored by Kalle Pilt. Parallel hands-on work: Reconstruction of arched ceiling (mirror vaults) by old technique, tutored by Mati Raal.	
14:00	<i>Lunch</i>	
15:00–18:00	Parallel hands-on work continues: Non-destructive evaluation of timber constructions (attic, ceilings, floors) of Seidla manor, tutored by Kalle Pilt. Parallel hands-on work continues: Reconstruction of arched ceiling (mirror vaults) by old technique, tutored by Mati Raal.	
18:00	Visit to Esna manor and Esna milieu valuable village	
20:00	Visit to Põhjaka manor. Final dinner at Põhjaka manor.	Põhjaka manor is renovated to a cosy eating place by three young and enthusiastic chef-cooks. The ideology of the place is to make simple and genuine but tasty dishes from fresh local foodstuff.
Day 6 / September 10, 2010		
7:45	<i>Breakfast</i>	
8:15	Check-out and departure from Jäneda to Seidla manor	
9:00–12:00	Parallel hands-on work continues.	
12:00	Summary	
13:00	<i>Lunch</i>	
14:00	Departure to manor tour: Vihula manor, Sagadi manor, Palmse manor	
21:00	Arrival in Tallinn. Accommodation in Go Hotel Shnelli	Go Hotel Shnelli's location: Internet www.gohotels.ee . Parking at the hotel.
	Student party	
Day 7 / September 11, 2010		
	Free time in Tallinn	

About Gotland University

Gotland University was established in 1998 and is one of the youngest universities in Sweden. It is located in the World Heritage city of Visby on the island of Gotland, a geologically and ecologically unique island that is surrounded by the Baltic Sea. Gotland's rich historical past and beautiful natural environment attracts visitors from all over the world. These features as well as the many yearly cultural manifestations that take place all over the island create and enhance a stimulating learning environment for students and teachers alike. Gotland is a very dynamic region that favours education and actively promotes national and international exchanges and collaboration.

As the first university in Sweden, Gotland University has adopted a Liberal Education philosophy. Its mission is to prepare the student for personal growth and professional success while engaging him/her in today's complex world. Multidisciplinary teaching will achieve this. It implies that besides compulsory courses, the students can select courses according to their interest. For example, a student wishing to become a designer and who has a strong interest in ecology could choose from among courses in design and construction in combination with courses in ecology and biology.

All year around, quality 'on-campus' and 'internet-based' programmes and courses are offered in Swedish and English. The choice includes a Master Programme in International Management and independent courses in Archaeology, Osteo-Archaeology, Cross Cultural Studies, IT/Business Administration, International Business Relations, European Studies, Game Design, Building Conservation, Object Antiquarian Studies, Russian, History, Human Geography, Ethnology, Ecology and Art History.

Outstanding lecturers and international experts come to teach at Gotland University. Theory and practice are readily combined through participation in local businesses and regional affairs. Innovative thinking and a great sense of commitment are typical characteristics of both students and staff, which are reflected in our

academic and working philosophy.

Gotland University strives to promote quality in its many international exchanges and cooperation projects, and has been approved as an Erasmus University Charter institution by the European Union. Academic credits are translated according to ECTS (the European Credit Transfer System).



Gotland University / Högskolan på Gotland

Cramérgatan 3

621 67 Visby, Sweden

Phone +46 498 29 99 00

Fax +46 498 29 99 62

www.hgo.se

About Estonian Academy of Arts

Established in 1914, the Estonian Academy of Arts is the only public university in Estonia providing higher education in fine arts, design, architecture, media, visual studies, art culture, and conservation.

The EAA is striving to become a leading international centre of innovation in the field of visual culture. Currently there are more than 1 200 students enrolled in the Academy, with many participating in exchange programmes at international partner universities. In addition to active study and research activities, the Estonian Academy of Arts also offers lifelong learning opportunities through the Open Academy.

The Estonian Academy of Arts collaborates with more than a hundred universities worldwide and belongs to several international higher education networks.

The lecturers and instructors are professionals in their field—internationally recognised artists, architects, designers, historians, and scientists. Visiting lecturers from universities in Estonia and abroad are regular guests.

The Estonian Academy of Arts has a rich academic library that is constantly expanding its collection, a newly renovated joint dormitory with the Estonian Music and Theatre Academy, and training grounds at Tamse in Muhumaa and Heimtal in Viljandimaa. Departments of the EAA regularly organise student, faculty, and departmental exhibitions in various locations in Tallinn and elsewhere.

The EAA actively publishes different types of publications, including faculty members' books, textbooks, study materials, collections of articles, and advance reviewed works from the fields of art and science.

In 2010/2011, there are more than 600 students in the Bachelor's programme, close to 300 in Master's programme, 46 in the Doctoral programme, and close to 290 students in the Open Academy.

While offering a wide selection of specialities, the Academy also offers unique, individualised study and personal mentorship by members of the faculty. The departments are strong bodies of competence on their own, while at the same time facilitating synergy and interdisciplinary studies. Many faculties have been operating

for close to a century. They have lengthy experience and historical continuity, and also pioneer change in their field.

The Academy welcomes motivated people who are visually and socially sensitive and want to develop their thinking abilities, opportunities, and potential as creative people. The goal of the Academy is for graduates to be able to function successfully in society and work as independent creators and thinkers. That is why the curricula are formed in such a way as to develop the analytical ability and critical thinking of students. Every programme includes philosophy, history of art, aesthetics, and foreign languages.



Estonian Academy of Arts / Eesti Kunstiakadeemia

Estonia pst 7 / Teatri väljak 1

EE-10143 Tallinn, Estonia

Phone +372 626 7301

Fax +372 626 7350

E-mail artun@artun.ee

EAA Skype: [kunstiakadeemia](https://www.skype.com/join/kunstiakadeemia)

www.artun.ee

This report deals with some aspects of the restoration of masonry buildings with windows, floors and roof trusses in wood. It is a product of good cooperation between students from Estonian Academy of Arts in Estonia, Gotland University in Sweden and Novia University of Applied Sciences in Finland. The report is a result of intensive course no. 2 within the joint project Sustainable Heritage which is financed by the Nordic Council of Ministers through Nordplus funds. Each chapter is written by students of different nationalities: the Estonian students concentrate on the necessary methodical approach that is vital in the documentation of building parts, the Swedish group gives a description of the performed hands-on mural work and the Finnish students look closer at the use of wood in historic buildings.

Rapporten handlar om några aspekter inom konsten att restaurera stenbyggnader med fönster, bjälklag och takkonstruktioner i trä. Den är en produkt av gott samarbete mellan studeranden från Estonian Academy of Arts i Estland, Högskolan på Gotland i Sverige och Yrkeshögskolan Novia i Finland. Rapporten är ett resultat av intensivkurs nr 2 inom skolornas samarbetsprojekt Sustainable Heritage, vilket stöds av Nordiska ministerrådet i form av Nordplus stipendier. Var och en studerandegrupp har skrivit ett avsnitt i rapporten: de estniska studerandena koncentrerar sig på den nödvändiga systematiken i inventeringsarbete, den svenska gruppen rapporterar om hands-on övningar i konsten att mura av sten medan de finska studerandena ser närmare på användningen av trä i historiska byggnader.



ISSN: 1799-4209

ISBN (online): 978-952-5839-44-9

YRKESHÖGSKOLAN
NOVIA